

User Manual

Wall Mounted Battery

FW5120 / FW10240



FLYFINE DIGITAL ENERGY CO.LTD

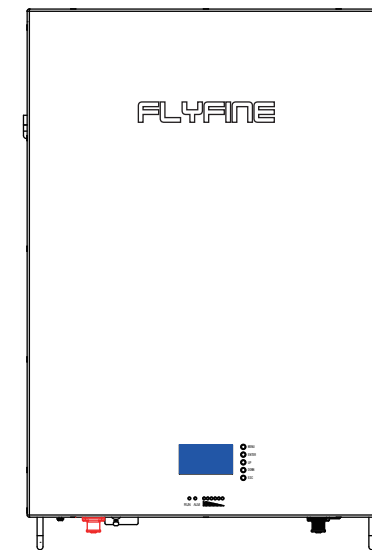
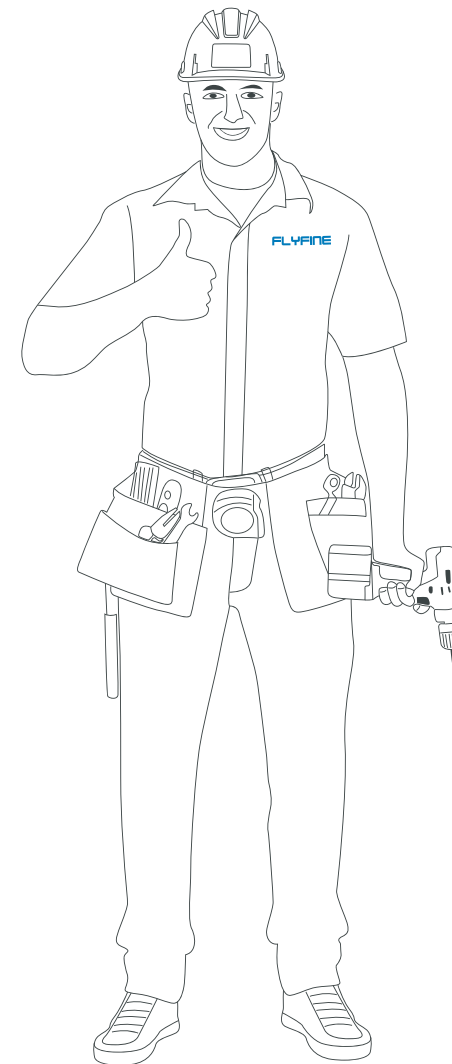

- 1 Instruction 02
- 2 Important Safety Warning 02
 - 2.1 Before Connecting 03
 - 2.2 During operation 04
- 3 Unpacking & Overview 04
 - 3.1 Packing List 04
 - 3.2 Product Overview 05
- 4 Installation 06
 - 4.1 Selecting Mounting Location 06
 - 4.2 Mounting The PACK 07
- Appendix 1 : BMS paramete 12
- Appendix 2 : Troubleshooting 15
- Appendix 3 : Emergency process 15

Note: please comply with all warings and operating instructions in this manual strictly. Save this manual properly and read carefully the following instructions before installing the unit. Do not operate this unit before reading through all safety information and operating instructions carefully.



Warning



Recyclable.



Read instruction before use.



Do not dispose battery in household trash.

1. Instructions

The Energy storage pack is an essential component of the photovoltaic power generation system. It can provide electricity for the connected load, and it can also store photovoltaic solar modules, fuel generators, or wind energy generators by charging the remaining energy in case of emergency. When the sun goes down, energy demand is high, or there is a power outage, you can use the energy stored in the system to meet your energy needs at no additional cost. In addition, the energy storage Pack can help you achieve energy self-consumption and ultimately achieve the goal of energy independence.

According to different power conditions, the energy storage PACK can output power during peak power consumption, and can also store energy during low power consumption. Therefore, when connecting the matching photovoltaic modules or inverter arrays, external equipment is required to match the energy storage the working parameters of the pack to achieve the highest operating efficiency. For a simple diagram of a typical energy storage system.

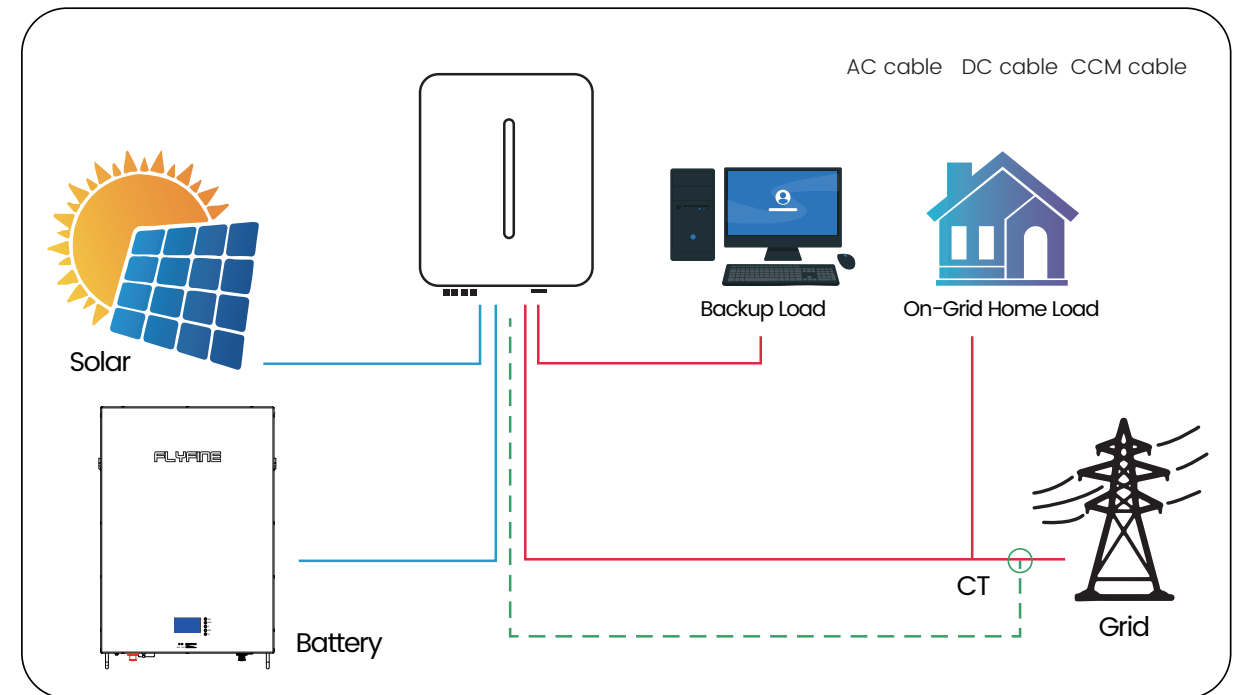

Energy storage System Overview

It is very important and necessary to read the user manual carefully before installing or using the battery. Failure to follow any of the instructions or warnings in this document can result in electrical shock, serious injury, death, or may damage the battery and the whole system.

- If the battery is stored for a long time, it is requirement that they are charged every three to six months, and the SOC should be no less than 80%, after fully discharging, The battery needs to be recharged within 12 hours.
- Do not expose cable outside; Do not use cleaning solvents to clean the battery.
- All battery terminals must be disconnected before maintenance.

2. Important Safety Warning

















- Do not expose the battery to flammable or harsh chemicals or vapors.
- Do not paint any part of the battery, include any internal or external components.
- Do not connect battery with PV solar wiring directly.
- Any foreign object is prohibited to be inserted into any part of the battery.
- Our company will not bear any warranty claims for direct or indirect damage caused by violation of the above items.



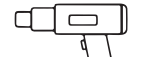
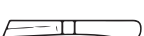

2.1 Before connecting

- After unpacking, please check the battery and pack list first, if the battery is damaged or spare parts are missing, Please contact the dealer.
- Before installation, be sure to cut off the grid power and make sure the battery is in the turned-off mode;
- Wiring must be correct, do not mix-connect the positive and negative cables, and ensure no short circuit with the external device;
- It is prohibited to connect the battery with AC power directly;
- The BMS in the battery is designed for 24VDC/48VDC, DO NOT connect battery in series;
- It is prohibited to connect the battery with different type of battery;
- Please ensure the electrical parameters of battery system are compatible to inverter. Keep the battery away from fire or water.

Necessary installation Tools.

 Clamp meter	 Multi-meter	 Label paper	 Phillips screwdriver
 COAX crimping tool	 Diagonal pliers	 Wire stripper	 Claw hammer
 Hammer drill	 Insulation tape	 Cotton cloth	 Brush
 Heat shrink tubing	 Heat gun	 Electrician's knife	 Protective gloves

Personal protective equipment

 Insulated gloves	 Safety goggles	 Safety shoes	 Helmet
---	---	---	--

Necessary installation environment

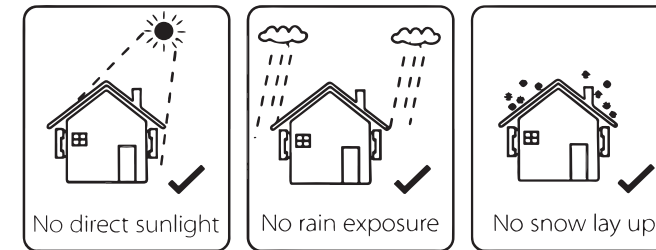







2.2 During operation

- If the battery system needs to be moved or repaired, the power must be cut off first and the battery is completely shutdown;
- It is prohibited to connect the battery with different type of battery;
- It is prohibited to put the batteries working with faulty or incompatible inverter;
- In case of fire, only dry powder fire extinguisher can be used, liquid fire extinguishers are prohibited;
- Please do not open, repair or disassemble the battery. We do not undertake any consequences or related responsibility due to violation of safety operation or violating of design, production and equipment safety standards.

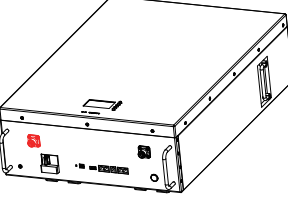
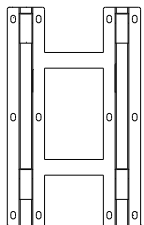
3. Unpacking & Overview

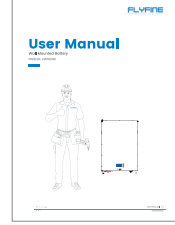
3.1 Packing List

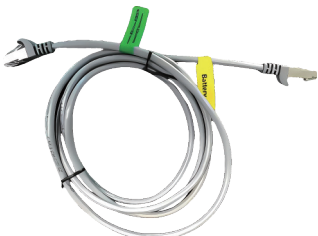
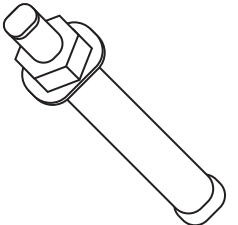
You will receive the following parts (Not a full set), sample as follow picture. For customized requirements, please place an order with the manufacturer.

Battery pack 	Mounting brackets 	Power out positive cable 
Power out Negative cable 	Manual *1 	Parallel common cable (RJ45) 
Inverter common cable (RJ45) 	Mounting frame screw 	The RS232 communication 

3.2 Product Overview

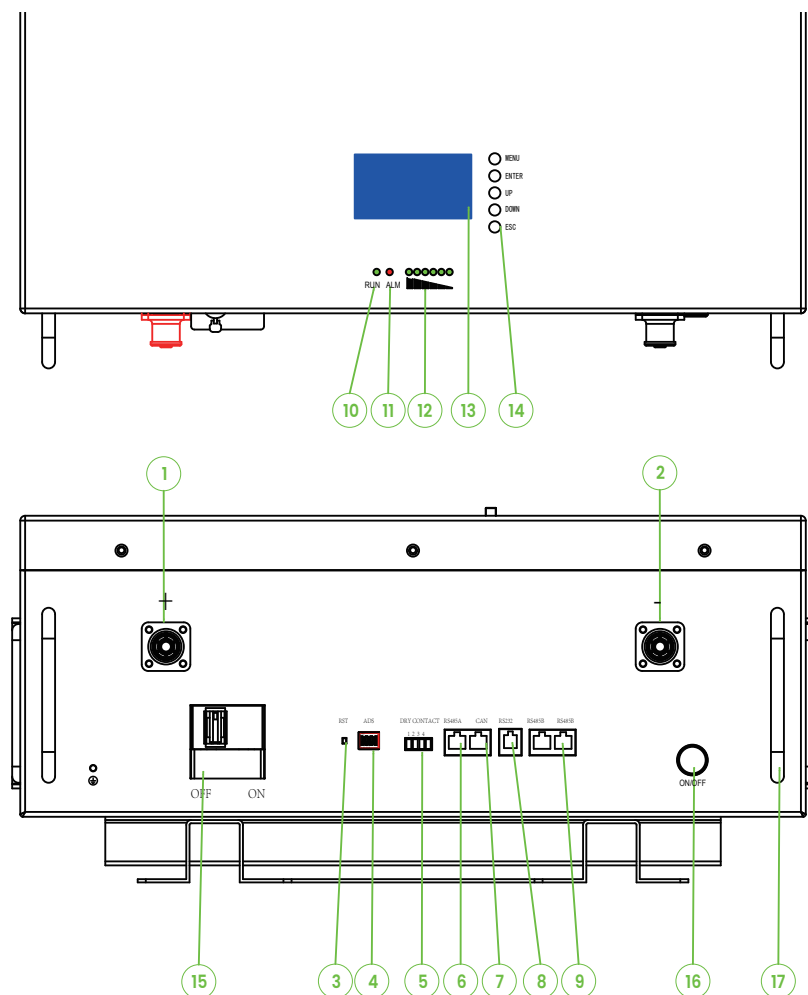

A General battery shape.Front view

	Description	Silk-screen	Remark
1	Output terminal	+ +	Output terminal
2	Output terminal	- -	Output terminal
3	Handle		
4	LED indicate	RUN	Operation indicator
5	LED indicate	ALM	Alarm indicator
6	LED indicate	CAPACITY	Capacity indicator
7	LCD		
8	LCD Key	MENU/Enter/UP/ESC	
9	Power Switch	ON/OFF	
10	Reset button	RST	For reset the batter
11	Dial switch	ADS	Set the address
12	Dry port	DRY CONTACT	
13	RS485A Port	RS485A	RS485A and inverter connection port

14	CAN bus Port	CAN	CAN bus and inverter connection port
15	RS232 Port	RS232	RS232 and computer connection port
16	RS485B Port	RS485B	battery and battery connection port
17	E-Switch	ON/OFF	

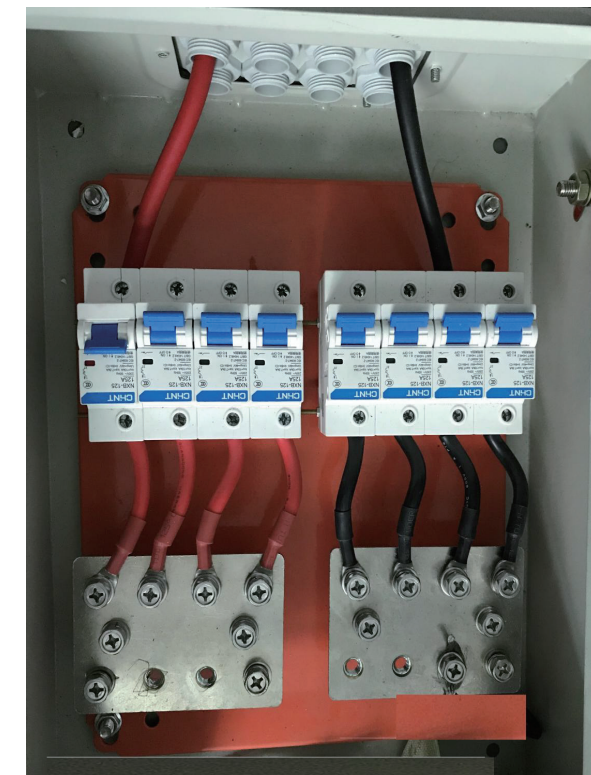
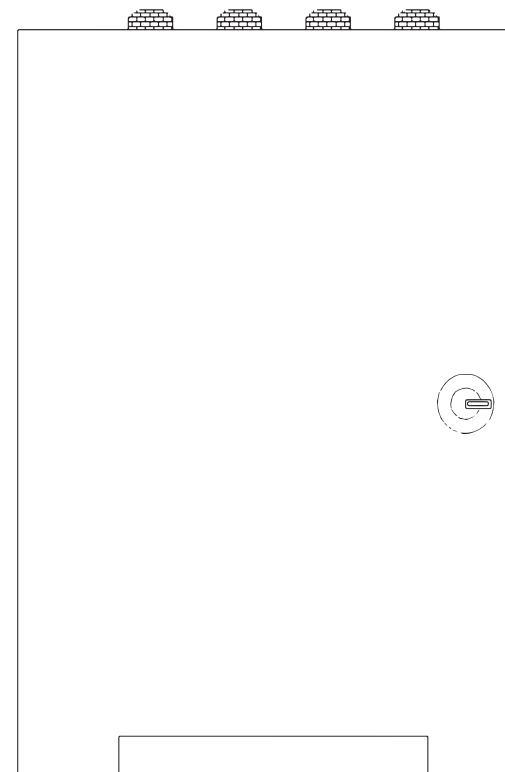

Combiner control box

4.Installation

4.1 Selecting Mounting Location

Consider the following points to install the energy storage Pack:

- Do not mount the Pack on flammable construction materials. Mount on a solid surface.
- Install this Pack module at eye level in order to allow the readability of LCD display at all times.
- For proper air circulation to dissipate heat, please leave a gap of about >0.3 meter from the ground,30 cm from the side of the device.
- The ambient temperature should be between 0°C and 40°C and relative humidity should be between 25% and 85% to ensure optimal operation.
- The recommended installation is flat wise adherence.
- Install the battery module in a dry, protected area with no excessive dust and sufficient air circulation. Do not operate in locations where the temperature and humidity are outside the specified range.

4.2 Mounting The PACK



WARNING!! Remember that this Pack is heavy so please be careful when removing it from the package, or install it

When installing the Pack bracket, use appropriate screws to fix it. After that, the equipment should be firmly bolted. The pack can be run indoors or outdoors. However, only professional personnel can enter this area for installation or maintenance.

Step 1:

- When receiving the product, first check whether all parts are complete, if not, please report to the Dealer.

Step 2:

- Ensure that the Pack is installed on the wall surface. Choose a suitable installation location and require the battery pack to be placed at a safe distance greater than 30cm from the ground, and the safety distance between battery packs is also greater than 30cm too. We recommend an installation distance is 50cm.

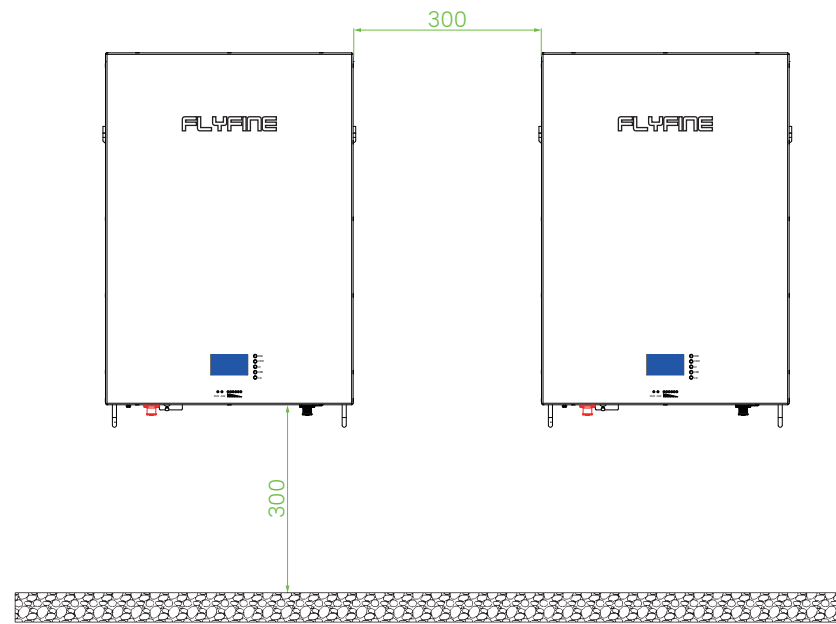

Step 3:

- Use the mounting bracket to mark the location of the positioning screw hole on the wall, and use an electric drill to drill the hole. Need to be drilled with a drill of appropriate diameter.

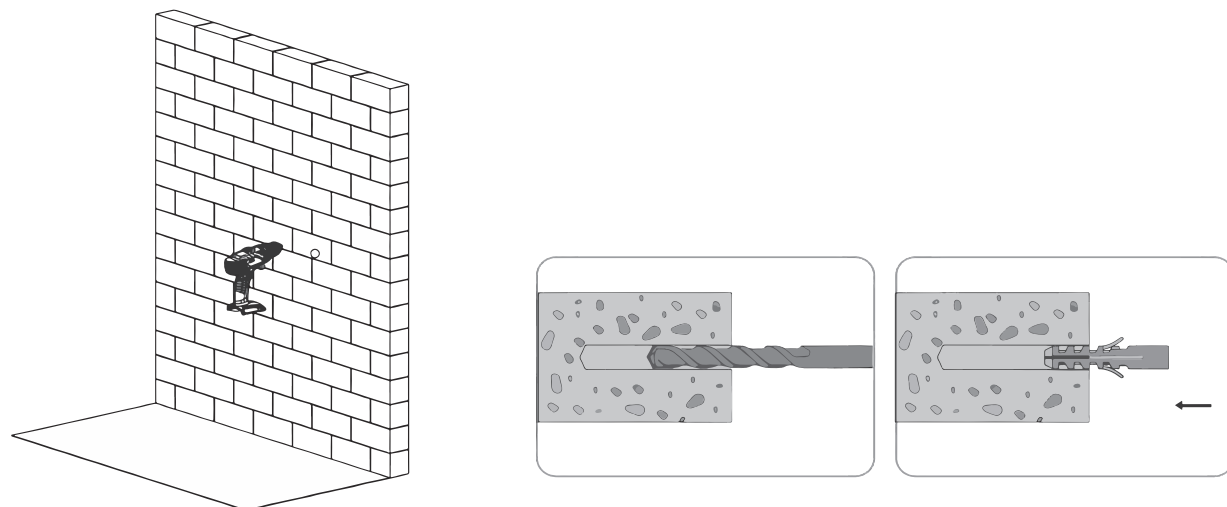

Step 4:

- Insert frame screws, then place the bracket, and use screws to lock it.

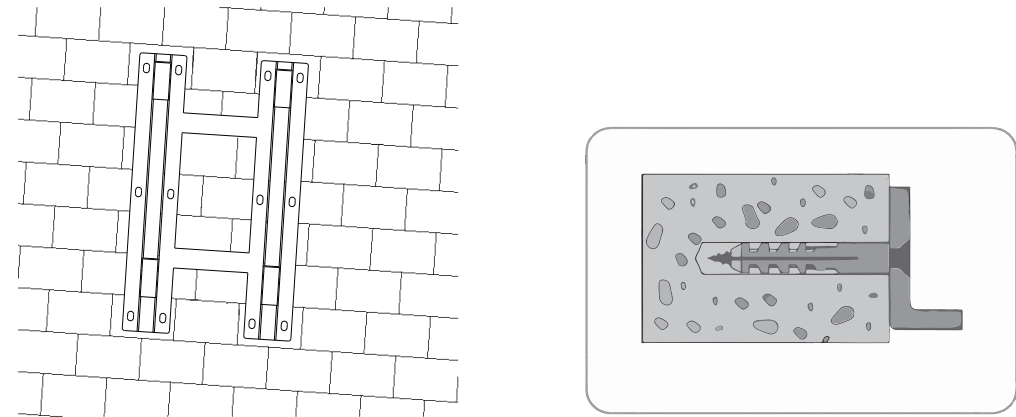

Step 5:

- As shown in the below, install the battery pack. The pack is too heavy, please use a special lifting device to lift the pack for operation and safety protection. Lift the pack and put it into the slot of the fixing bracket from the front. You can install more packs as shown.



Step 6:

- When more than 3 PCS packs are connected in parallel, then we recommend you install a combiner box. 3 locations we recommend you install the combiner box. First select location is Top and Bottom.

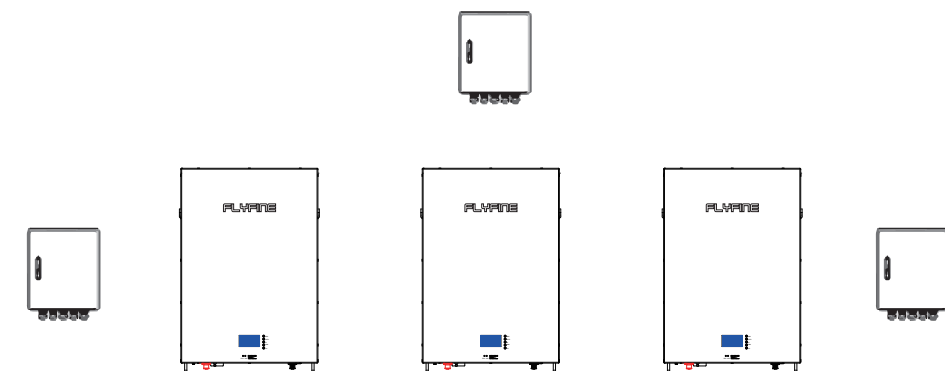

Step 7 :

- Connect the wiring of the Pack as shown below. See figure 11. If inverter need CAN BUS port/RS485B only be used for battery packs parallel mode.

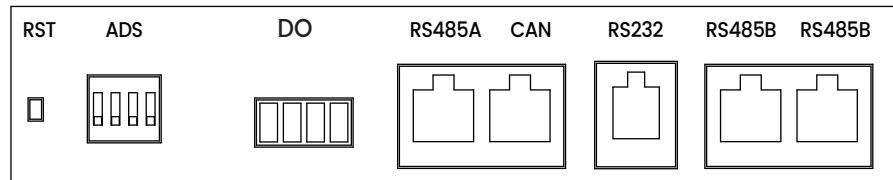

CAN And RS485A---Communicate with external devices, sample as inverter ,EPS
 RS232---Communication with host computer
 RS485B---Communication with host computer or parallel communication with battery pack

1pack---1 Inverter. Single mode.

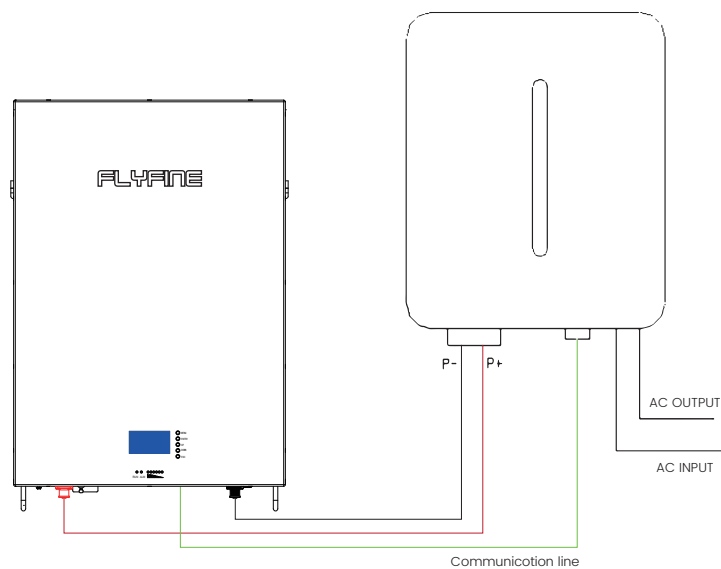

2pack---3 Inverter. Mainly writing for 3-phase inverter. Pack 1,2 is slave; pack 3 is master. More pack are parallel, one pack is master, other are slave. 3-phase inverter output 380VAC. One inverter is master, other are slave. Please refer to the operation manual of the inverter, there is only an example.



•Step 8:

Set the address of pack. This is an important step, you can see there is 4bit or 8bit coder in bottom of Pack. Please set as bill 1 and 2. 4 bit CODER: this is Binary CODER, Calculated by 8 4 2 1 BCD code. PACK 1 set as Master (BCD 1 0 0 0), see bill 1. It supports 15 PCS pack (max) in parallel. Address "0" is only used for single mode.

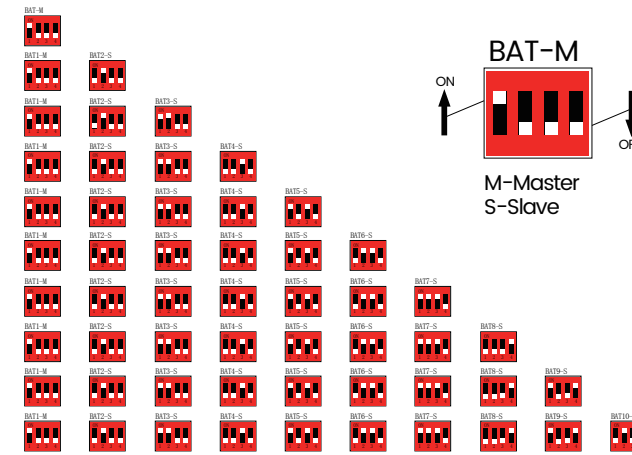

ID地址	Position of the DIP switch 拨码开			
	#1	#2	#3	#4
1	ON	OFF	OFF	OFF
2	OFF	ON	OFF	OFF
3	ON	ON	OFF	OFF
4	OFF	OFF	ON	OFF
5	ON	OFF	ON	OFF
6	OFF	ON	ON	OFF
7	ON	ON	ON	OFF
8	OFF	OFF	OFF	ON
9	ON	OFF	OFF	ON
10	OFF	ON	OFF	ON

This is 4bits coder and communication port. CAN port and RS485A port can be selected as the same time.

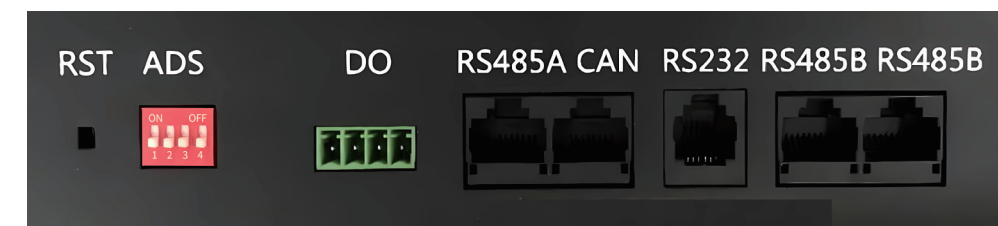

Parallel communication	RJ45	RS485B-8P8C	
		RS485-B	RS485-A
	1,8	9,16	RS485-B
	2,7	10,15	RS485-A
	3,6	11,14	GND
	4,5	12,13	NC

External communication	RJ45	RS485A port		CAN port	
		RS485-B1	RS485-A1	RJ45	
	1,8	9,10,11,14,16			
	2,7	12			CAN-L
	3,6	13			CAN-H
	4,5	15			GND

Communication with host computer	RJ11	RS232		
		RJ11		
	1	NC	4	RX
	2	NC	5	GND
	3	TX	6	NC

NOTE: The output connected to the communication cable with a waterproof plug is listed according to the order requirements, which are customized products, and are not listed here.

Step 9:

- Connect the parallel communication cable (yellow network line). Any Pack has 2 PCS RS485B port for parallel communication, 1 PCS RS485A and 1PCS CAN port for inverter or other device. RS232 port only used for host software and update the firmware.

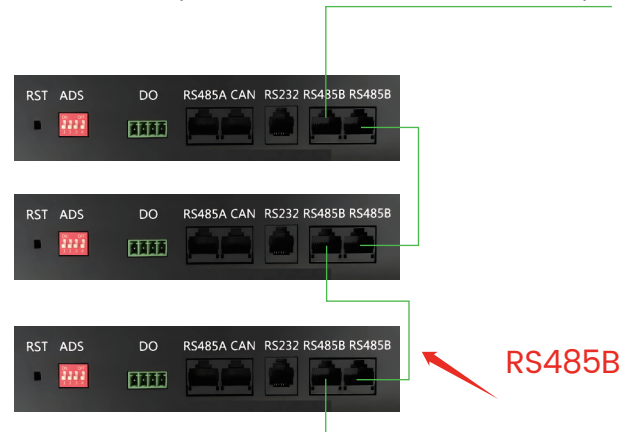

Step 10:

- Start and stop battery pack. Confirm that the operation is correct, and the battery function can be turned on after the wiring is correct, and you can press down power switch (ON/OFF) 3 seconds to start battery pack, then turn on switch in the combiner box, the battery starts working and outputs, it enters standby mode (if there is no power switch, please use a little pole and press down the RESET key 3-6 seconds, like as follow picture, LED indicates all running status and check itself).

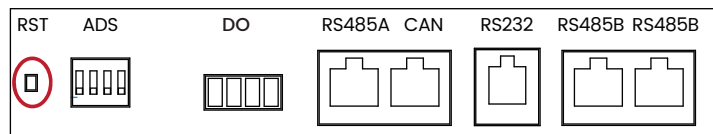

Step 11:

- Running the device, set the external charger or inverter parameters, please set according to the corresponding operation manual. Can not exceed the rated parameter requirements.

Battery Pack parameters:

No	Item	General Parameter
1	Combination method	51.2V
2	Rated Capacity(Ah)(typical)	100
3	Factory Voltage(V)	51-53V
4	Rate power(Wh)	5120
5	Charging Voltage(V) recommend/max	57/57.6V
6	Charging Current(A) recommend/max	0.5C
7	Float charge Voltage(V)	55.5V
8	Discharge Cut-off Voltage(V)	≤44V
9	Max Discharging current(A)	100A
10	Internal Impedance	≤20mΩ
11	Communication protocol	CAN/485
12	Host software and Communication protocol	RS232/485
13	Operation Temperature Range	Charge: 0~55°C
		Discharge: -20~55°C
14	Storage Temperature Range(recommend)	0°C~25°C

Battery Pack parallel parameters:

No	Item	General Parameter
1	Combination method	51.2V
2	Rated Capacity(Ah) Parallel	PACK*Parallel
3	Factory Voltage(V)	51-53V
4	Charging Voltage(V) recommend/max	57/57.6V
5	Charging Current(A) recommend/max	0.1C/0.2C (total)
6	Float charge Voltage(V)	56V
7	Discharge Cut-off Voltage(V)	≤50V
8	Max Discharging current(A)	90*Parallel
9	Internal Impedance	≤20mΩ
10	Communication protocol	CAN/485
11	Host software and Communication protocol	RS232/485
12	Operation Temperature Range	Charge: 0~55°C
		Discharge: -20~55°C
13	Storage Temperature Range(recommend)	0°C~25°C

Battery Pack support communication with inverter: (More communication protocols need to be proposed separately)

NO.	Specification
1	SMA
2	MUST
3	Victron
4	Schneider
5	DeYe
6	Growatt

Step 12:

- Monitor all running status, and record all parameters, if there has any mistake, please record it. After start the system, every pack is on, and led indicates these status.

Step 13:

- Stop running battery pack. When it is necessary to stop the charging and discharging of the battery or troubleshooting, please stop the external equipment first, cut off the input and output circuits, and then press the power switch off each battery pack.

Appendix 1

BMS parameters.

LED indicate, picture of 4bit coder.

Chart 1: Battery Status

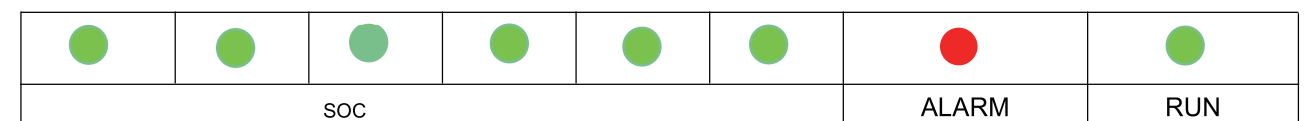

Chart 2: Battery Capacity

status	charge						discharge					
	L6	L5	L4	L3	L2	L1	L6	L5	L4	L3	L2	L1
SOC(%)	●	●	●	●	●	●	●	●	●	●	●	●
0-16.6%	OFF	OFF	OFF	OFF	OFF	Flash 2	OFF	OFF	OFF	OFF	OFF	light
16.6-33.2%	OFF	OFF	OFF	OFF	Flash 2	light	light	OFF	OFF	OFF	light	light
33.2-49.8%	OFF	OFF	OFF	Flash 2	light	light	light	OFF	OFF	OFF	light	light
49.8-66.4%	OFF	OFF	Flash 2	light	light	light	light	OFF	OFF	light	light	light
66.4-83%	OFF	Flash 2	light	light	light	light	light	OFF	light	light	light	light
83-100%	Flash 2	light	light	light	light	light	light	light	light	light	light	light
RUN LED	light						Flash(flash 3)					

Chart 3: LED flash and buzzer mode (Off by default)

MODE	ON	OFF	MODE	ON	OFF
Led Flash1	0.25S	3.75S	Buzzer1	0.25S	0.25S
Led Flash2	0.5S	0.5S	Buzzer2	0.25S	2S
Led Flash3	0.5S	1.5S	Buzzer3	0.25S	3S

Chart 4: LED flash mode

System status	Run status	ON/OFF	RUN	ALM	SOC						REMARK
		●	●	●	●	●	●	●	●	●	
Power off	SLEEP	OFF	OFF	OFF	OFF	OFF	OFF	OFF	OFF	OFF	All led off
Stand by	NORMAL	Light	Flas h1	OFF	Lighting for SOC						stand by mode
	ALARM	Light	Flas h1	Flas h3	Lighting for SOC(The LED flash2,while it is the high SOC)Alarm LED do not flash,when the BMS into OVP mode.						Low volt alarm
CHARGE	NORMAL	Light	Light	OFF	Lighting for SOC						No charge in, into standby
	ALARM	Light	light	Flas h3	Lighting for SOC						
	OVP	Light	Light	OFF	Light	Light	Light	Light	Light	Light	
Discharge	OTP,OC P,Fail	Light	OFF	Light	OFF	OFF	OFF	OFF	OFF	OFF	Stop charge
	NORMAL	Light	Flas h3	OFF	Lighting for SOC						Disc harge off
	ALARM	Light	Flas h3	Flas h3	Lighting for SOC						
	UVP	Light	OFF	OFF	OFF	OFF	OFF	OFF	OFF	OFF	
FAIL	OTP,OC P, SCP,Fail	Light	OFF	Light	OFF	OFF	OFF	OFF	OFF	OFF	Discharge off
		OFF	OFF	Light	OFF	OFF	OFF	OFF	OFF	OFF	NO Charge or discharge

Chart 5: LCD screen display

1. Display rendering



2. Main menu page

After BMS is activated, wil show the welcome screen, press the "MENU" button to enter the main menu page.

As shown in the figure below:

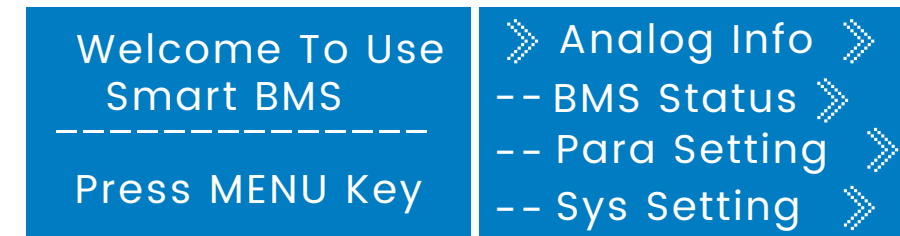

3. Battery parameters page

When the cursor "》" is point to "Battery Parameters Acquisition", press "ENTER" key will enter the page of "Battery Parameters Acquisition", As shown in the figure below:

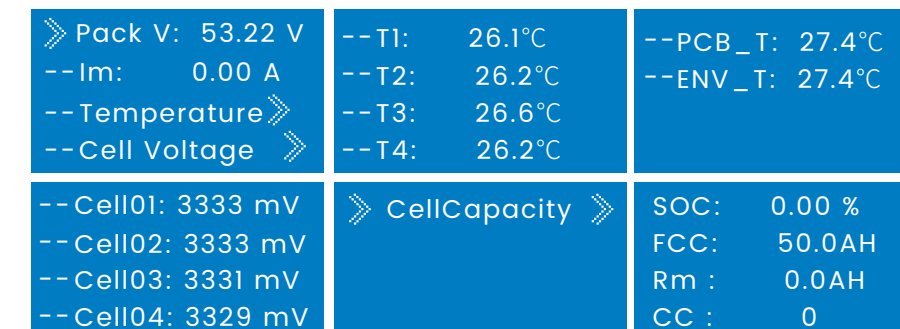

When the cursor "》" is point to "Battery Status", press "ENTER" key will enter the page of "Battery Status",

As shown in the figure below:

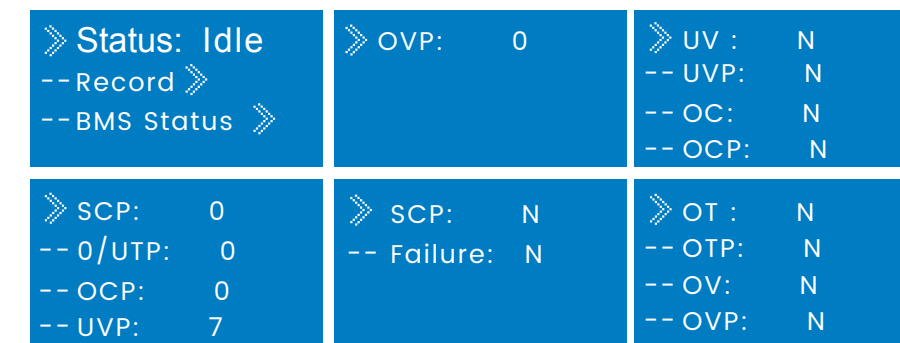

Parameter Settings

Screen can not set parameters Baud Rate: 9600, Can not be set.

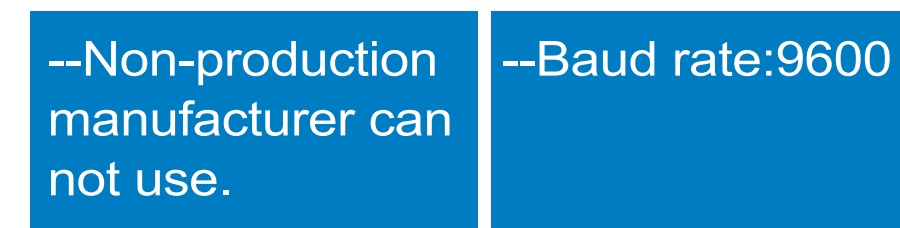

Key description

- 1) SW1----MENU, SW2----ENTER, SW3----UP, SW4----DOWN, SW5---- ESC
- 2) Each item is "》" or "--" as a beginning, among them "》" shows the current cursor position, press "UP" or "DOWN" key can move the cursor position; with "》" end of the project, the content of the said project hasnot shown, press "ENTER" key can enter the corresponding page.
- 3) Press "ESC" key can be returned at the next higher level directory; In any position, press "MENU" key canreturn to the main menu page.
- 4) When BMS inter sleep mode, press any key, can activate the screen. Inter standby mode , with no keystrokes 1 minutes later, LCD will enter Shutdown mode press any key,screen can be activated.

Appendix 2

• A Host soft operation:

When the equipment manufacturer confirms that it is necessary, it can authorize to provide the customer with the host software and operating instructions.

名称	修改日期	类型	大小
Config	2022/2/25 11:23	文件夹	
PbmsTools V2.5FN	2020/3/2 15:59	应用程序	669 KB
PbmsTools V2.5FN.exe.config	2021/12/17 16:31	CONFIG 文件	1 KB

• B Host soft operation:

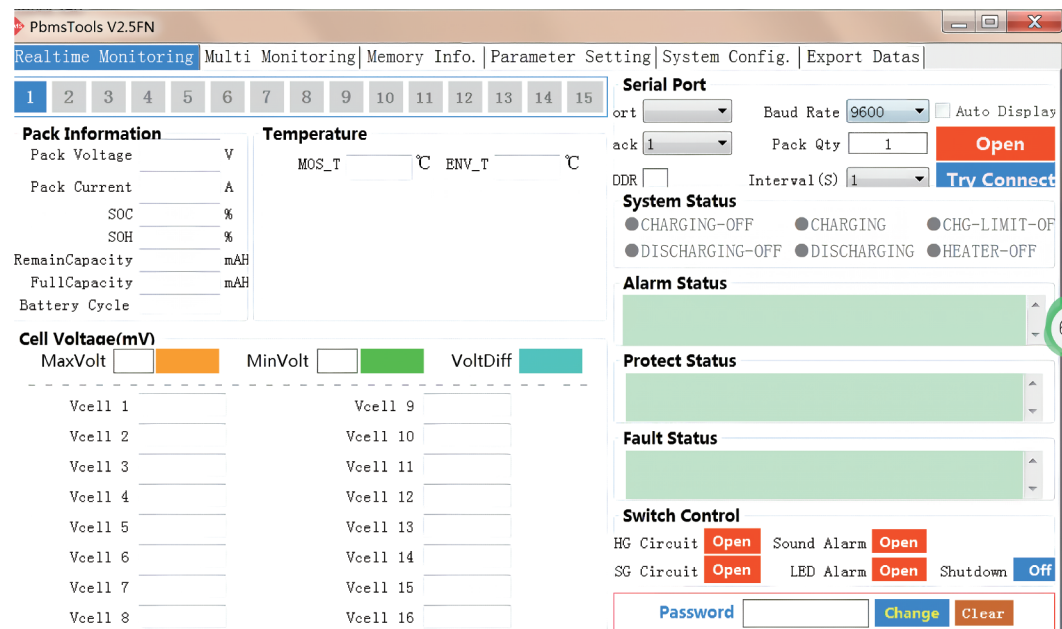

Appendix 3

Troubleshootin

1. Battery pack stop work.

- A: Turn on switch, be sure it is ON; If battery is low SOC, it needs charging in.
- B: Battery pack low volt or enter sleep mode, there you will press down "RST" button 3-6 second, or charging in.

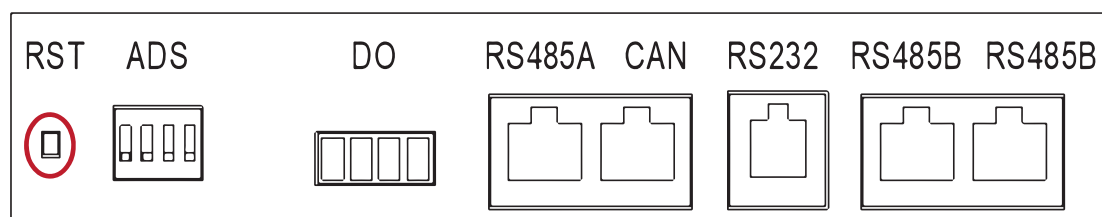

2. No communication, inverter can not received any DATA from BMS.

- A: Check whether if communication cable is OK, check RJ45 PIN,
CAN: PIN4:CANH,485A-A
PIN5:CANL;485-B
RS485A: PIN2:485A-A
PIN1:485A-B;
- B: Replace the communication line. Please give feedback to the dealer and exchange it.
- C: Check inverter or other device which connect to BMS, update its firmware.
- D: If the communication function needs to be upgraded, please consult the agent or manufacturer.
- E: Confirm your inverter and battery protocol is correct, different protocol or different connection will make a mistake.

3. Battery pack report SOC is mistake.

- A: Inverter received Data from Master BMS, but it is SOC < total SOC, sample as: 9PCS packs has 1800Ah, but inverter read DATA is 1600Ah. So you may check any one is disconnected, check RS485B communication cable (yellow), RS485 communication cable, replace the cable which is broken. RJ45 PIN:
CAN: PIN4:CANH,
PIN5:CANL;
RS485A: PIN2:485-A,
PIN1:485-B;
- B: SOC DATA has large tolerance.
Discharge empty the battery first, then charge it fully with a small current, and learn to discharge. Any pack is mistake, we advise you read the BMS Data (When we authorize the terminal to use) with host software, then we reset the BMS and calibration.
- C: When multiple batteries are connected in parallel, the SOC is different.
We recommend that each pack has a small current discharged and it is emptied until the SOC alarm appears, and then recharged in parallel and fully charged.

4. How to turn on the Pack to discharge.

- We recommend method is:
- A: Reset the single pack's BMS, LED will flash and start work
- B: Turn on the power switch on the bottom/front panel;
- C: Turn on power switch in the combiner box.

WARNING: The operating parameters of the equipment cannot exceed the rated working voltage and current of the Pack, exceed the rated volt and current, can cause damage to the Pack or other failures.

5. Inverter or other external device can not connect the battery.

- We recommend method is:
- A: Check whether the working parameter's of the device and battery are appropriate, and improper parameters cannot be matched.
- B: When the device is turned on, the current is too large, resulting in battery protection, at this time, you should be able to see the LED flashing from the battery panel. In this case, you can adjust your equipment parameters or contact the dealer to solve.
- C: It is necessary to update BMS parameters and match the device, then reset BMS and restart your device.

6. Replace bad Pack.

- There is a bad battery pack, it is need to replace, please connect your supplier, need professional installers to operate it. We recommend replace all or make pack has same voltage and same specification batteries pack.
- NOTE: When replacing the battery, the same module needs to be replaced at the same time, and the voltage should be the same.

7. Need to replace spare parts or emergency maintenance.

- Some parts can be obtained from the sales or agency, and the excess parts need to be purchased separately.
- Be careful, turn off the power switch before replacing parts.

8. Need to place some safety device for keep a safe environment.

- You'd keep a safe case for Pack and external device, please place safety device, as: fire-fighting sand, fire-fighting blankets, fire-fighting water pipes, install Monitor sound, light, electricity, smoke and other equipment.

WARNING:

Emergency process:

1. The external device catches fire and explodes:

- A: Under the condition of ensuring safety, non-operating personnel immediately move to a safe location.
- B: Under the condition of ensuring safety, the operator immediately cut off the external power supply of the equipment and the internal power supply.
- C: Use fire-fighting equipment for fire-fighting treatment (the use of fire-fighting sand, fire-fighting blankets, fire-fighting water pipes)
- D: If you cannot completely extinguish the fire, please call the local fire department for help.
- E: Keep the accident site data so that the source of the accident can be traced.

2. The Pack catches fire and explodes:

- A: Under the condition of ensuring safety, non-operating personnel immediately move to a safe location.
- B: Under the condition of ensuring safety, the operator immediately cut off the external power supply of the equipment and the internal power supply.
- C: Use fire-fighting equipment for fire-fighting treatment (the use of fire-fighting sand, fire-fighting blankets, fire-fighting water pipes)
- D: If you cannot completely extinguish the fire, please call the local fire department for help.
- E: Keep the accident site data so that the source of the accident can be traced.

END