

User Manual

Single Phase Hybrid All In One ESS

FBA10240 / FAB20480



FLYFINE DIGITAL ENERGY CO.LTD

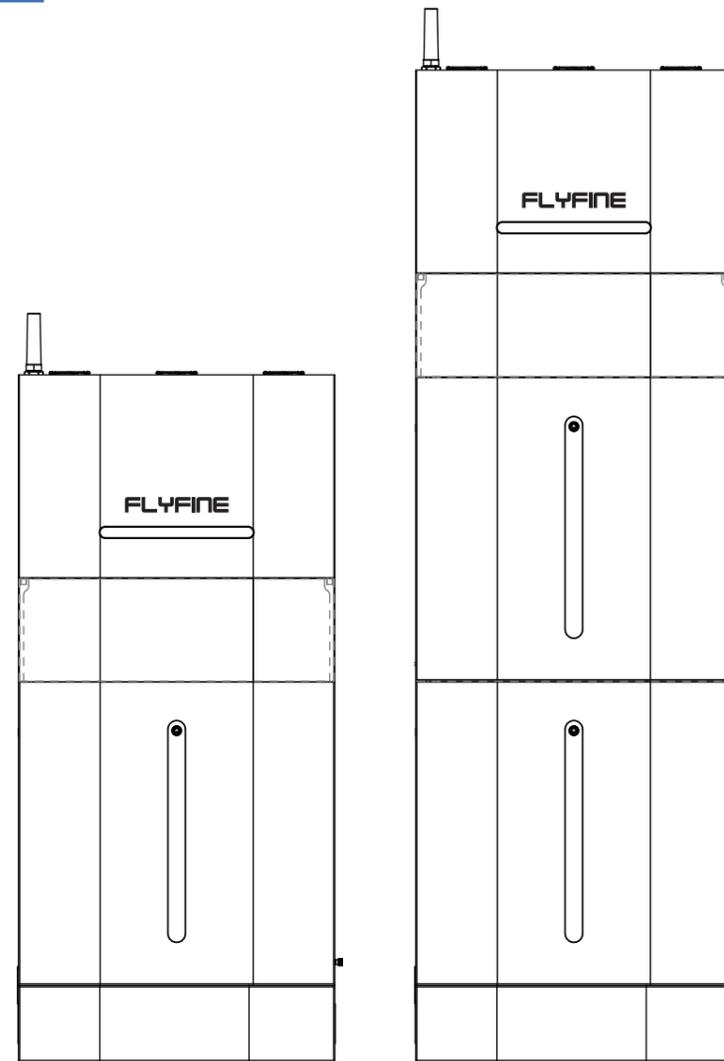

All Rights Reserved

• All Rights Reserved

No part of this document can be reproduced in any form or by any means without the prior written permission of Flyfine Digital Energy Co.,Ltd. (hereinafter "FLYFINE").

• Trademarks

FLYFINE and other FLYFINE trademarks used in this manual are owned by FLYFINE.

All other trademarks or registered trademarks mentioned in this manual are owned by their respective owners.

• Software Licenses

- It is prohibited to use data contained in firmware or software developed by FLYFINE, in part or in full, for commercial purposes by any means.
- It is prohibited to perform reverse engineering, cracking, or any other operations that compromise the original program design of the software developed by FLYFINE.

About This Manual

The manual primarily encompasses product information, along with installation, operation, and maintenance guidelines.

It will refer to the device as the "ESS" unless otherwise specified.

• Target Group

This manual is intended for professional technicians who have responsibilities for the installation, operation, and maintenance of inverters, as well as users who need to check inverter parameters.

The installation of the ESS should only be carried out by professional technicians who meet the following requirements.

- Possess knowledge of electronics, electrical wiring, and mechanical expertise, and be familiar with electrical and mechanical schematics.
- Have received professional training related to the installation and commissioning of electrical equipment.
- Capable of promptly responding to hazards or emergencies that may arise during the installation and commissioning process
- Familiar with local standards and relevant safety regulations pertaining to electrical systems.
- Thoroughly read this manual and understand the safety instructions associated with the operations.

• Symbols

This manual incorporates crucial safety instructions that are emphasized using specific symbols. These symbols are employed to ensure the safety of individuals and property during product usage or to assist in maximizing product performance efficiently.

It is essential to thoroughly comprehend the significance of the warning symbols to enhance your utilization of the manual.

Change History

Changes between document issues are cumulative, meaning that each subsequent document issue includes all the changes made in earlier issues.

V1.0 (2023-09-15)

This version is the first official release.

V1.1 (2023-09-26)

Modify 9.1 Technical Data Table.

- 1 Safety Instructions 01
 - 1.1 Unpacking and Inspection 01
 - 1.2 Installation Safety 02
 - 1.3 Electrical Connection Safety 02
 - 1.4 Operation Safety 03
 - 1.5 Maintenance Safety 04
 - 1.6 Disposal Safety 04
- 2 Product Description 05
 - 2.1 System Introduction 05
 - 2.2 Product Introduction 06
 - 2.3 Symbols on the Product 07
 - 2.4 Hybrid Inverter 08
 - 2.4.1 LED Panel 08
 - 2.4.2 DC Switch 09
 - 2.5 Battery 09
 - 2.5.1 Battery Parallel 09
 - 2.5.2 BMS Comm. Address 10
 - 2.5.3 BMS Comm. Interface 10
 - 2.5.4 SOC Indicator & Status Indicator Guides 11
 - 2.6 PV Energy Storage System (PV & ESS) 11
 - 2.6.1 PV Energy Storage System (PV & ESS) 11
 - 2.6.2 Declaration For EPS Function 12
 - 2.6.3 Energy Management 12
- 3 Function Description 14
 - 3.1 Safety Function 14
 - 3.1.1 Protection 14
 - 3.1.2 Earth Fault Alarm 14
 - 3.2 Energy Conversion and Management 15
 - 3.2.1 Power Derating 15
 - 3.2.2 Regular Operational Voltage Range 15
 - 3.2.3 Regular Operational Frequency Range 15
 - 3.2.4 Reactive Power Regulation 16
 - 3.3 Communication and configuration 16
 - 3.4 Battery Management 16
 - 3.4.1 Charge Management 17
 - 3.4.2 Discharge Management 17
- 4 Unpacking and Storage 18
 - 4.1 Unpacking and Inspection 18
 - 4.2 Scope of Delivery 19
 - 4.3 Product Storage 20

- 5 Mechanical Mounting 21
 - 5.1 Safety during Mounting 21
 - 5.2 Location Requirements 21
 - 5.2.1 Environment Requirements 22
 - 5.2.2 Carrier Requirements 22
 - 5.2.3 Angle Requirements 22
 - 5.2.4 Clearance Requirements 23
 - 5.3 Installation Tools 23
 - 5.4 Moving the Ess 24
 - 5.5 Installing the Ess 25
- 6 Electrical Connection 28
 - 6.1 Safety Instructions 28
 - 6.2 The battery module connects to the inverter 29
 - 6.2.1 Preparation 29
 - 6.3 Utility Grid Connection 30
 - 6.3.1 Preparation 30
 - 6.3.2 Connecting to the AC Utility 30
 - 6.4 PV Module (DC) Connection 32
- 7 Commissioning 35
 - 7.1 Inspection before commissioning 35
 - 7.2 Powering on the system 35
 - 7.3 Download App 35
 - 7.4 Registration 36
 - 7.5 Create a Plant 36
 - 7.6 Add a Logger 37
 - 7.7 Network configuration 37
 - 7.8 stick Logger installation 38
 - 7.9 Logger status 39
 - 7.9.1 Check Indicator light 39
 - 7.10 Abnormal state Processing 39
- 8 System Decommissioning 40
 - 8.1 Disconnecting the Ess 40
 - 8.1.1 Disconnecting the Ess 40
 - 8.1.2 Dismantling the Ess 41
 - 8.1.3 Disposal of the ESS 41
 - 8.2 Decommissioning the Battery 41
- 9 Appendix 42
 - 9.1 Technical Data 42

1 Safety Instructions

Before using please read all instructions and cautionary markings on the unit and this manual. Store the manual where it can be accessed easily.

This manual is for qualified personnel. The tasks described in this manual may be performed by qualified personnel only.

Conventions used:

WARNING!

Warnings identify conditions or practices that could result in personal injury;

CAUTION!

Caution identify conditions or practices that could result in damage to the unit or other equipment connected.

WARNING

- Avoid operating the product and cables (including but not limited to product movement, installation, operation, powering up, maintenance, and working at heights) under harsh weather conditions such as lightning, rain, snow, and level 6 or stronger wind.
- In case of fire, evacuate the building or the area where the product is located and immediately contact the fire department. Under no circumstances should re-entry into the burning area be attempted.

NOTICE

- Ensure that the product and terminals are securely fastened using the specified torque and appropriate tools. Failure to do so may result in product damage, and any resulting damage will not be covered by the warranty.
- Familiarize with the correct usage of tools to prevent injury to individuals or damage to the device.
- Maintain the device with sufficient knowledge of this manual and use proper tools.
 - The safety instructions provided in this manual are supplementary and may not encompass all precautions that should be followed. Always consider the actual on-site conditions when performing operations.
 - We will not be held liable for any damages caused by the violation of general safety operation requirements, general safety standards, or any safety instructions stated in this manual.
 - When installing, operating, and maintaining the product, comply with local laws and regulations. The safety precautions provided in this manual serve as supplements to local laws and regulations.

1.1 Unpacking and Inspection

WARNING

Before decommissioning the device, carefully inspect all safety signs, warning labels, and nameplates to ensure they are in place and clearly visible. These signs and labels should not be removed or covered at any time.

NOTICE

Upon receiving the product, conduct a thorough inspection to verify the condition of the device's appearance and structural components. Additionally, compare the contents of the packaging with the ordered product to ensure consistency. If there are problems with the above inspection items, do not install the device and contact your distributor first. If the problem persists, contact us for further assistance.

1.2 Installation Safety

DANGER

- Before installation, ensure that there is no electrical connection present.
- Before drilling, take precautions to avoid any water or electrical wiring in the wall.

CAUTION

Improper installation can result in personal injury!

- If the product supports hoisting for transportation using hoisting tools, it is strictly prohibited for anyone to remain under the product.
- When moving the product, take into account its weight and maintain balance to prevent tilting or falling.

NOTICE

Prior to operating the product, it is crucial to inspect and verify that the tools to be used have undergone regular maintenance.

1.3 Electrical Connection Safety

DANGER

Before making electrical connections, it is essential to ensure that the ESS is undamaged to prevent potential dangers!

Before electrical connections, confirm that all switches connected to the ESS are set to the "OFF" position to avoid the risk of electric shock!

DANGER

The PV string generates a lethal high voltage when exposed to sunlight. Please observe the following safety precautions during electrical connections.

- Operators must wear appropriate personal protective equipment.
- Use a measuring instrument to verify that cables are voltage-free before touching DC cables.
- Adhere to all safety instructions provided in relevant documents concerning PV strings.

DANGER

There is a risk of high voltage inside the ESS that can be life-threatening. Please take note of the following precautions!

- Use specialized insulation tools during cable connections.
- Follow and strictly adhere to the warning labels on the product and the safety instructions.
- Respect all safety instructions stated in this manual and other relevant documents.

DANGER

Batteries deliver electrical power and can cause burns or fire hazards when short-circuited or incorrectly installed. Lethal voltages are present at the battery terminals and cables connected to the ESS. Avoid touching the cables and terminals to prevent severe injuries or death.

WARNING

- Damage to the product resulting from incorrect wiring is not covered by the warranty.
- Electrical connections should be performed by professionals.
- All cables used in the PV generation system must be securely attached, properly insulated, and adequately sized.

WARNING

Ensure to check the positive and negative polarity of the PV strings and connect the PV connectors to the corresponding terminals only after confirming the correct polarity. During the installation and operation of the ESS, prevent the positive or negative poles of PV strings from short-circuiting to the ground to avoid AC or DC short-circuits that could lead to equipment damage. Such damage is not covered by the warranty.

NOTICE

Comply with the safety instructions regarding PV strings and adhere to the regulations applicable to the local grid.

1.4 Operation Safety

DANGER

- Do not touch the enclosure of the ESS while it is running.
- It is strictly prohibited to plug or unplug any connectors on the ESS while it is running.
- Avoid contact with any terminals of the ESS while it is running to prevent electric shock.
- Do not disassemble any parts of the ESS while it is running, as it may result in electric shock.
- Refrain from touching any hot parts of the ESS, such as the heat sink, while it is running to avoid burns.
- If the ESS is equipped with a DC switch, do not operate it while it is running to prevent device damage or personal injury.

1.5 Maintenance Safety

DANGER

There is a risk of ESS damage or personal injury resulting from incorrect service procedures!

- Prior to performing any service work, disconnect the grid-side AC circuit breaker and check the status of the ESS. If the ESS indicator is off, wait until nighttime before disconnecting the DC switch. If the ESS indicator is on, you can directly disconnect the DC switch.
- After the ESS has been powered off for at least 10 minutes, use a professional instrument to measure the voltage and current. Only when there is no voltage or current detected, and operators are wearing proper protective equipment, can they proceed with operating and maintaining the ESS.
- Even if the ESS is shut down, it may still be hot and cause burns. Wear protective gloves before operating the ESS after it cools down.

DANGER

Touching the power grid or the contact points and terminals on the ESS connected to the power grid can result in electric shock!

The power grid side may have voltage. Always use a standard voltmeter to ensure there is no voltage before touching.

CAUTION

To prevent misuse or accidents caused by unauthorized personnel, prominently display warning signs or designate safety warning areas around the product.

NOTICE

To avoid the risk of electric shock, refrain from performing any maintenance operations beyond those described in this manual. If necessary, contact your distributor first. If the issue persists, contact us for maintenance. Failure to do so may result in losses that are not covered by the warranty.

1.6 Disposal Safety

WARNING

Please dispose of the product in accordance with the applicable local regulations and standards to prevent property losses or injuries.

2 Product Description

2.1 System Introduction

This energy storage system can provide power to connected loads by utilizing PV power, utility power and battery power and store surplus energy generated from PV solar modules for use when needed. When the sun has set, energy demand is high, or there is a black-out, you can use the energy stored in this system to meet your energy needs at no extra cost. In addition, this energy storage system helps you pursue the goal of energy self-consumption and ultimately energy independence.

Depending on different power situations, this energy storage system is designed to generate continuous power from PV solar modules (solar panels), battery, and the utility. When MPP input voltage of PV modules is within acceptable range (see specification for the details), this energy storage system is able to generate power to feed the grid (utility) and charge. This energy storage system is only compatible with PV module types of single crystalline and poly crystalline. Do not connect any PV array types other than these two types of PV modules to the energy storage system, Do not connect the positive or negative terminal of the solar panel to the ground, See Figure 1 for a simple diagram of a typical energy storage system.

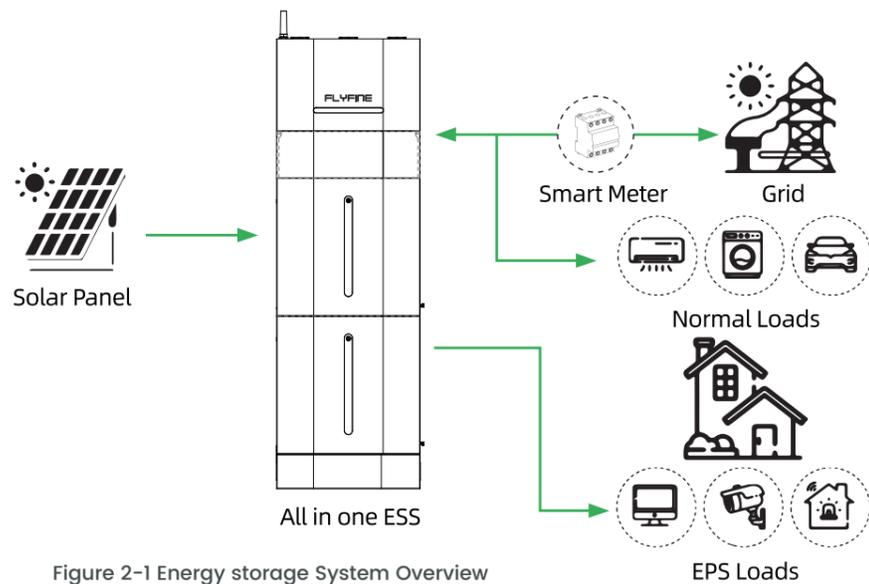

Figure 2-1 Energy storage System Overview

WARNING

- Operate the ESSs only with PV strings having class II protection (IEC 61730, application class A). Avoid grounding the positive or negative poles of the PV strings to prevent damage to the ESS.
- Warranty does not cover damages caused by faulty or damaged PV installations.
- Only use the ESS as described in this document; any other use is not permitted.
- During installation and operation, ensure that the positive and negative polarities of PV strings and batteries do not short-circuit to the ground to avoid equipment damage. Warranty does not cover damage resulting from such short-circuits.
- Avoid short-circuiting the EPS port during operation to prevent severe damage to the ESS or power distribution system, Such damage is not covered by the warranty.

NOTICE

- In a TT utility grid, ensure that the N line voltage to ground is 30V or below.
- For off-grid applications, the utility grid must be a TN system.
- The system is not suitable for powering life-sustaining medical devices, and it does not guarantee EPS power in all situations.
- The ESS is designed for the specific scenarios described in this manual.

2.2 Product Introduction

Model Description

The model description is follows (take FAB20480 as an example):

FAB: All-in-one Energy Storage System

20480: 10kWh*2 Battery PACK

Power level is 6Kw

2: include two battery PACK or 20KWh Battery.

Appearance

The image show here is for reference only, The actual product received may differ.

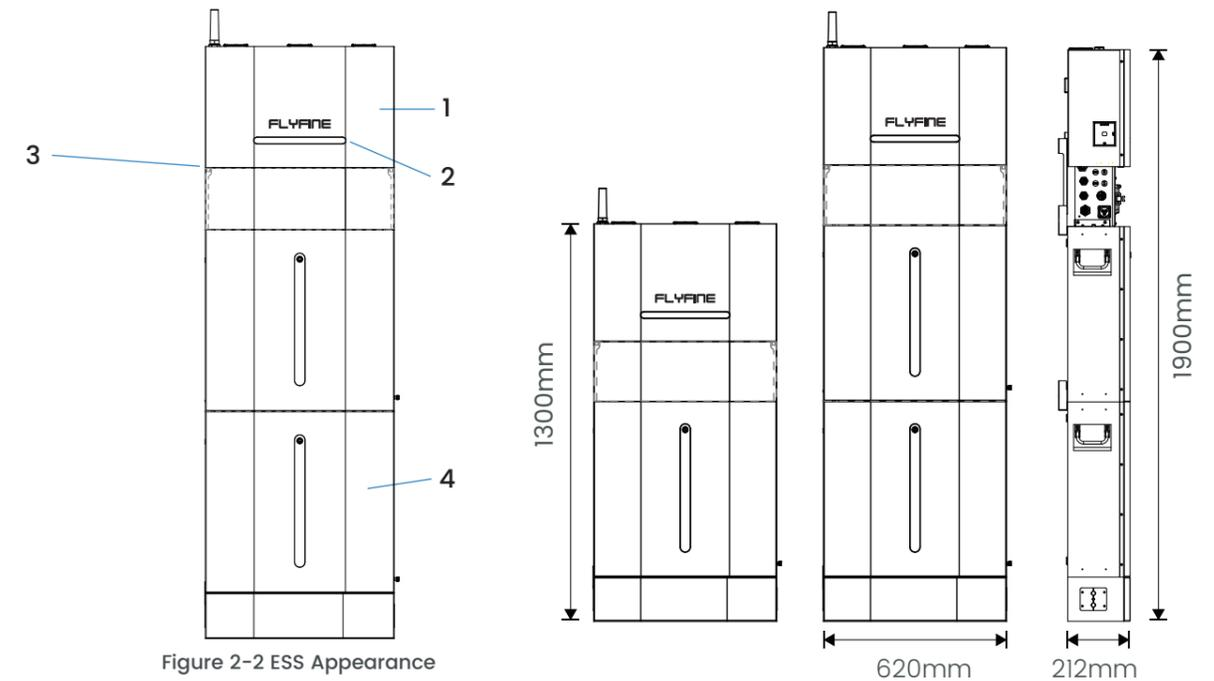

Figure 2-2 ESS Appearance

No.	Name	Description
1	Hybrid Inverter	Indicates the current operating state of the inverter.
2	LED indicator panel	Indicates the current operating state of the ESS.
3	Electrical connection area	Includes DC terminals, AC terminals, battery terminals, communication terminals and additional grounding terminal.
4	Battery	A Li-ion battery.

Dimensions

The following table shows the dimensions of the ESS

Model	W(mm)	H(mm)	D(mm)
FBA10240	620	1300	212
FAB20480	620	1900	212

2.3 Symbols on the Product

Symbol	Explanation
	Parameters on the PV side
	Parameters on the Battery side
	Parameters on the AC on-grid side
	Parameters on the AC EPS side
	Danger to life due to high voltages Do not touch live parts for 10 minutes after disconnection from the power sources Only qualified personnel can open and maintain the ESS
	Read the user manual before maintenance!
	There is a deadly high pressure danger! Only professional and qualified personnel are allowed to install and operate!
	RoHS mark of conformity
	Regulatory compliance mark
	UKCA mark of conformity
	CE mark of conformity
	Do not dispose of the ESS together with household waste
	TÜV mark of conformity

2.4 Hybrid Inverter

2.4.1 LED Panel

The LED panel with a display screen and an indicator is on the front of the inverter.

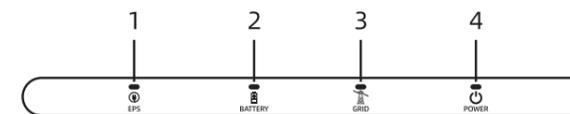

Figure 2-3 LED Panel

No.	Name	Description
1	EPS	EPS state
2	BATTERY	Battery state
3	GRID	Grid state
4	POWER	Inverter power state

- In normal operation, the LED indicator will alternate the EPS, Battery, Grid, Power state information.
- In the event of no user activity for 5 minutes, the display screen will automatically turn off to conserve power. Users can reactivate the display screen by simply touching the LED indicator.

The following chart description of the LED indicator

LED indicator	State	Description
EPS	Off	EPS load off
	Steady on	EPS load on
	Fast flashing	Frequency: 500ms EPS overload
	Slow	Frequency: 3s Undefined, reserved
BATTERY	Off	Battery not connected
	Steady on	Battery connected, in normal state
	Fast	Frequency: 500ms Battery failure
	Slow	Frequency: 500ms Battery failure
GRID	Off	Grid not connected, inverter operating in off-grid mode
	Steady on	Grid connected, inverter operating in grid-tied mode
	Fast	Frequency: 500ms Grid failure
	Slow	Grid connected, inverter operating in grid-tied mode, but no input power from the grid
POWER	Off	Inverter not powered on
	Steady on	Inverter powered on, in standby or normal operation
	Fast	Frequency: 500ms Inverter failure
	Slow	Frequency: 3s Inverter in self-checking mode
	Flashes once, pauses for three times	PV not connected

WARNING

Please be aware that voltage may still be present in the AC side circuits even after the indicator is turned off. It is crucial to prioritize electrical safety precautions during operation.

2.4.2 DC Switch

The DC switch serves as a means to safely disconnect the DC circuit whenever required. To initiate the inverter's operation, it automatically functions when the input and output requirements are met. However, in the event of a fault or when there is a need to halt the inverter, rotating the DC switch to the "OFF" position will stop its operation.

Note:
Turn the DC switch to the "ON" position before restarting the ESS.

2.5 Battery

2.5.1 Battery Parallel

The maximum capacity of a single system is 20 kilowatt hours. If the system capacity needs to be increased, it can be increased by adding battery modules. As shown in the figure:

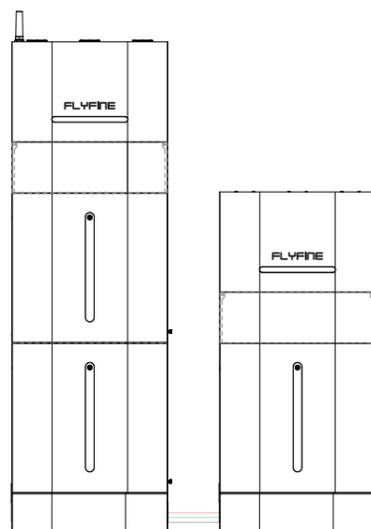

Figure 2-4 Battery Parallel

NOTICE

ORANGE cable to the positive terminal (+)
BLACK cable to the negative terminal (-)

2.5.2 BMS Comm. Address

After all wiring installation is complete, set up ID for each battery module. The ID code for each battery module MUST be unique. Not the same number for 2 battery modules in parallel system. Refer below chart for the details.

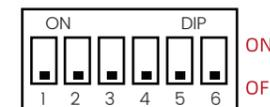

Address	Dial switch position				Reserve	Host	Illustrate
	#1	#2	#3	#4			
0	OFF	OFF	OFF	OFF	OFF	OFF	Reserve(Pack0)
1	ON	OFF	OFF	OFF	OFF	OFF	Slave(Pack1)
2	OFF	ON	OFF	OFF	OFF	OFF	Slave(Pack2)
3	ON	ON	OFF	OFF	OFF	OFF	Slave(Pack3)
4	OFF	OFF	ON	OFF	OFF	OFF	Slave(Pack4)
5	ON	OFF	ON	OFF	OFF	OFF	Slave(Pack5)
Inverter communication protocol selection CAN communication (selected by dialing 5 and 6 in host mode)							
7	ON	ON	ON	OFF	OFF	OFF	
8	OFF	OFF	OFF	ON	OFF	ON	
9	ON	OFF	OFF	ON	ON	OFF	
10	OFF	ON	OFF	ON	ON	ON	

Figure 2-5 BMS Comm. Address

2.5.3 BMS Comm. Interface

If there is any change in the pin position of the communication line, the customer shall be notified in writing or provided with supporting communication wire.

	RS485B interface	RS485-8P8C			
		RJ45 Pin	Definition Description	RJ45 Pin	Definition Description
Parallel communication		1	RS485A_B	5	NC
		2	RS485A_A	6	NC
		3	NC	7	RS485A_A
		4	NC	8	RS485A_B
Communication with host computer		1	RS485B_B	5	NC
		2	RS485B_A	6	NC
		3	NC	7	RS485B_A
		4	NC	8	RS485B_B
External communication		CAN-8P8C			
		RJ45 Pin	Definition Description	RJ45 Pin	Definition Description
		1	RS485A_B	5	CAN_L
		2	RS485A_A	6	NC
		3	NC	7	RS485A_A
		4	CAN_H	8	RS485A_B

2.5.4 SOC Indicator & Status Indicator Guides

Chart 1: Pack led indicate

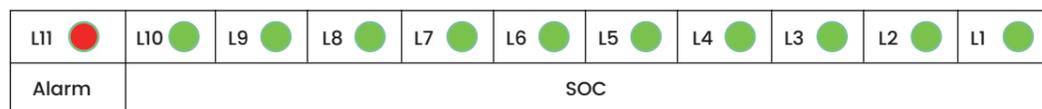

Chart 2: Pack Capacity indicate:

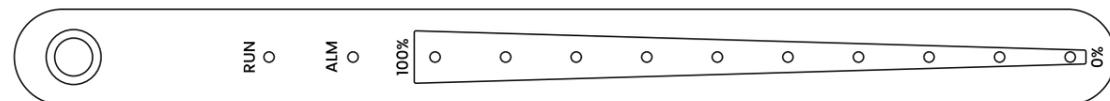

Chart 3: LED flash and buzzer mode

MODE	ON	OFF	MODE	ON	OFF
Led Flash1	0.25S	3.75S	Buzzer1	0.25S	0.25S
Led Flash2	0.5S	0.5S	Buzzer2	0.25S	2S
Led Flash3	0.5S	1.5S	Buzzer3	0.25S	3S

2.6 PV Energy Storage System (PV & ESS)

2.6.1 PV Energy Storage System (PV & ESS)

The following figure shows ESS application in a PV energy storage system.

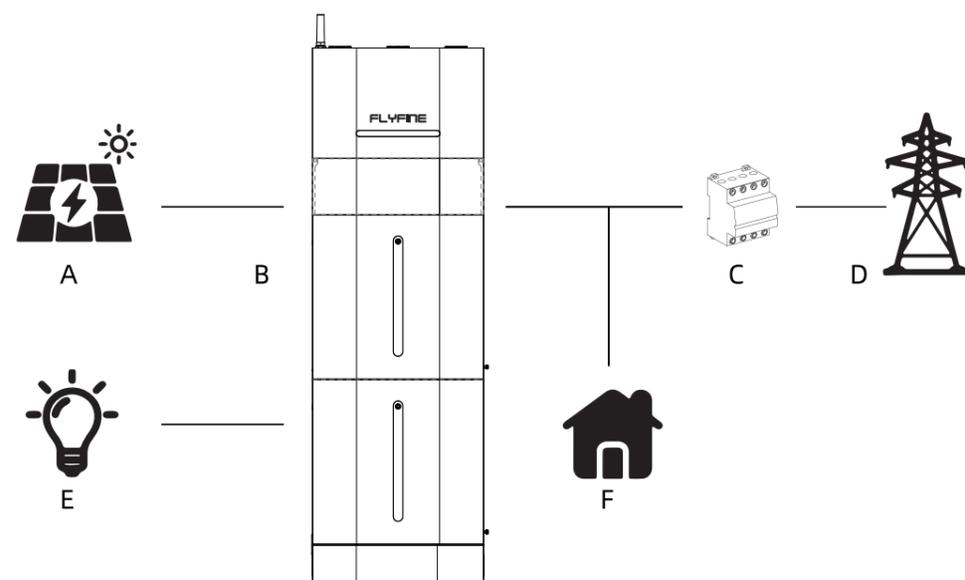

Figure 2-5 PV Energy Storage System

Item	Description	Note
A	PV strings	Compatible with monocrystalline silicon, polycrystalline silicon, and thin-film modules without grounding.
B	All in one ESS	FBA10240 / FAB20480
C	Metering device	Meter cupboard with power distribution system.
D	Utility grid	TT, TN-C, TN-S, TN-C-S
E	EPS Loads	Loads, connected to EPS port, which need uninterrupted power supply
F	Normal Loads	Some unimportant loads

2.6.2 Declaration For EPS Function

DANGER

This product is not intended for supplying power to life-sustaining medical devices. Power outages may pose a risk to life when relying on this product for such purposes.

The following statements outline our general policies concerning the ESS described in this document:

- 1: For the ESS, the electrical installation typically involves connecting the inverter to PV modules. In EPS mode, if there is no available power from batteries or PV modules, the EPS power supply will be automatically terminated. We bears no responsibility for any consequences resulting from failure to comply with this instruction.
- 2: Normally, the switching time for activating the EPS mode is less than 10 ms. However, certain external factors may cause the system to fail in EPS mode. Therefore, users must be aware of the following conditions and adhere to the instructions:
 - Do not connect loads that require a stable energy supply for reliable operation.
 - Do not connect loads whose total capacity exceeds the maximum EPS capacity.
 - Do not connect loads that may cause high start-up current surges, such as air conditioners, high-power pumps, vacuum cleaners, and hair dryers.
 - Battery current may be limited due to factors including temperature and weather conditions.

Declaration For EPS Overload Protection

In the event of overload protection, the hybrid inverter will automatically restart. If overload protection is repeatedly triggered, the restart time may increase (up to a maximum of 10 minutes). To avoid this, reduce the power of the EPS load to remain within the specified limits or remove loads that may cause high start-up current surges.

2.6.3 Energy Management

NOTICE

- The battery discharges to provide energy to loads. If the battery is empty or there is not enough power from the battery system, the grid shall supply power to EPS loads and normal loads.
- When the grid is available, the hybrid inverter activates the bypass function. This allows the EPS loads to be directly connected to the grid via the integrated bypass switch in the inverter.
- If the Smart Energy Meter is either not present or experiencing abnormalities, the ESS will continue to operate normally. However, the battery will only be allowed to charge and not discharge. In this scenario, the feed-in power setting becomes ineffective, and the DO function for optimized mode will be disabled

Energy Management during Daytime

The energy management system (EMS) defaults to self-consumption mode. The following scenarios illustrate the energy management process:

- Scenario 1: PV power generation > Load power consumption:
 - First, PV power is prioritized for the EPS loads first, followed by normal loads and then the battery.
 - If the battery is fully charged, any excess power will be fed back to the grid. The feed-in power will not exceed the feed-in limitation value set in the initial settings.
- Scenario 2: PV power generation < Load power consumption:
 - In this case, the battery will discharge to compensate for the energy shortfall.
 - If the combined power from the PV and battery is still insufficient to meet the load power demand, the inverter will draw power from the mains (grid) to make up for the deficit.

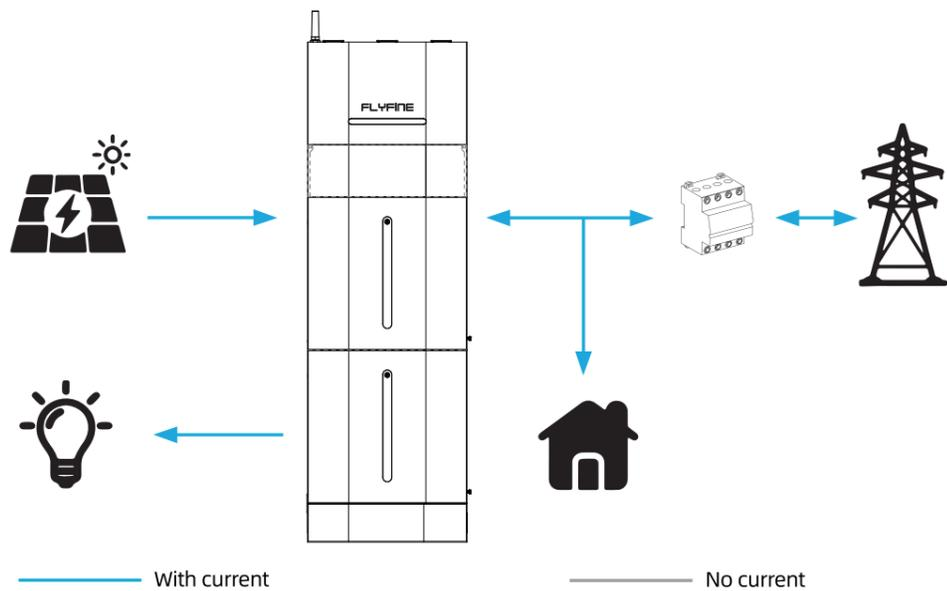

Figure 2-6 EMS During Daytime

Energy Management during Night

During the nighttime period, energy management operates as follows:

- Battery Discharge: With available energy, the battery will discharge to provide power for the loads. It acts as the primary source of power during this time.
- Grid Power Supply: If the discharge power of the battery is insufficient to meet the load requirements, the grid will automatically supply power to the loads. This ensures a continuous and uninterrupted power supply, even if the battery capacity is depleted or unable to sustain the load demand.

By combining the discharge capability of the battery and the EPS power from the grid, the system ensures reliable and continuous power supply during nighttime operations.

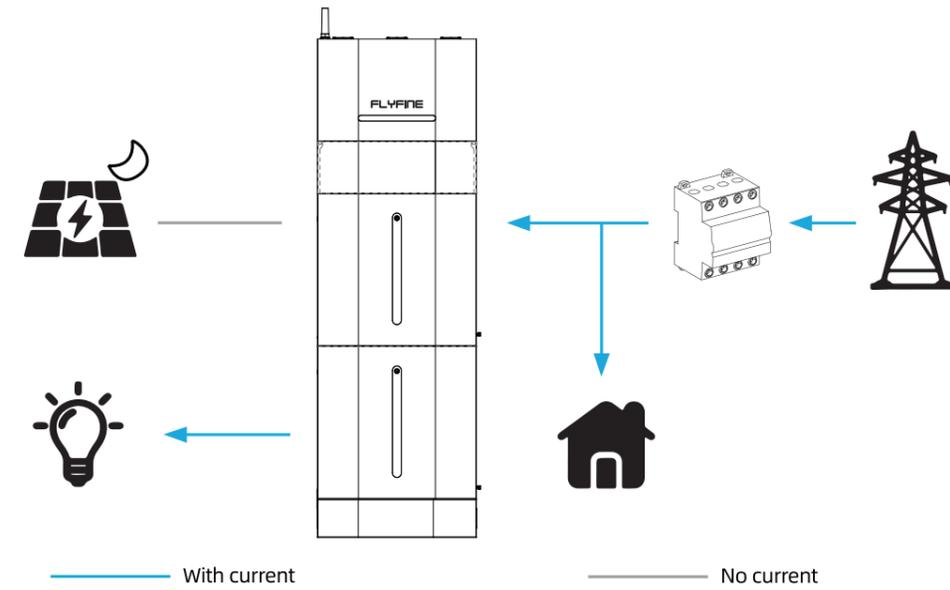

figure 2-7 EMS During Night

During night, when the battery is empty, it will enter into standby mode. In this case, the grid will supply all power for loads.

3 Function Description

3.1 Safety Function

3.1.1 Protection

Several protective functions are integrated in the ESS, including short circuit protection, grounding insulation resistance surveillance, residual current protection, anti-islanding protection, DC over-voltage / over-current protection, etc.

3.1.2 Earth Fault Alarm

The device is equipped with a grounding fault alarm system. In the event of inadequate or nonexistent grounding on the AC side, an audible alarm will sound and the LED indicator will illuminate in red.

3.2 Energy Conversion and Management

The ESS efficiently transforms the DC power derived from either the PV array or the battery into AC power that meets the specifications of the grid. Additionally, it facilitates the transfer of DC power from the PV panel to the battery.

Incorporating a bidirectional converter, the ESS has the capability to both charge and discharge the battery, ensuring optimal utilization of energy.

To maximize the power output from PV strings that may have varying orientations, tilts, or module structures, the ESS employs multiple string Maximum Power Point (MPP) trackers. These trackers enable the ESS to extract the maximum available power from each PV string, thereby enhancing overall system efficiency.

3.2.1 Power Derating

Power derating is implemented as a protective measure to safeguard the ESS against potential overload or faults. Moreover, the derating function can be activated in accordance with the requirements specified by the utility grid. Various situations that may necessitate ESS power derating include:

- Over-temperature conditions, which encompass both ambient temperature and module temperature.
- High input voltage levels.
- Grid under-voltage occurrences.
- Grid over-frequency events.
- Power factor deviations from the rated values.
- High altitude environments.

For seamless integration with demand response capabilities, the ESS is equipped with a terminal block designed to connect to a demand response enabling device (DRED). This DRED facilitates the activation of demand response modes (DRMs). When triggered, the ESS promptly detects and initiates a response to all supported demand response commands within a swift 2-second timeframe.

3.2.2 Regular Operational Voltage Range

The ESS are designed to operate effectively within the allowable voltage range for a specified observation time. The specific conditions for setting these voltage range parameters depend on whether the connection is for a normal operational start-up or an automatic re-connection following a tripping event triggered by interface protection.

If the voltage level deviates from the defined operational levels, the ESS will disconnect from the grid within the protection time frame. In the event of a short-lived disturbance that lasts for a duration shorter than the required protection time, the ESS can automatically reconnect to the grid once the voltage level returns to normal operating levels after the disturbance subsides.

3.2.3 Regular Operational Frequency Range

The ESS is designed to operate within its specified frequency range for a minimum observation time. The specific conditions for setting these frequency range parameters depend on whether the connection is for a normal operational start-up or an automatic re-connection following a tripping event triggered by interface protection.

If the frequency level falls outside the defined operational range, the ESS will disconnect from the grid. In the case of a temporary disturbance that lasts for a duration shorter than the required protection time, the ESS can automatically reconnect to the grid once the frequency level returns to normal operating levels after the disturbance subsides.

3.2.4 Reactive Power Regulation

The ESS offers reactive power regulation modes to provide grid support. The specific reactive power regulation mode can be configured and adjusted through the SOLARMAN Smart App.

3.3 Communication and Configuration

The ESS offers RS485, Ethernet, WLAN, and CAN ports for device and system monitoring. These ports allow configuration of parameters for optimal operation. ESS information is accessible through the SOLARMAN Smart App.

The import power refers to the total power obtained from the grid, which encompasses the power used to charge the battery from the grid through the ESS, the power consumed by local loads, and the power supplied to loads connected to the ESS's EPS port from the grid. To comply with local regulations, it is necessary to calculate the maximum allowable system power based on the wire size and circuit breaker required for the selected model. This value can be configured as the Import Power Limit, which can be conveniently adjusted using the SOLARMAN Smart App.

3.4 Battery Management

LiFePo4 battery are compatible with the PV ESSs, further battery models will be made compatible in the future. To optimize battery lifespan, the ESS will conduct battery charging, discharging, and maintenance activities based on the battery status information received from the Battery Management System(BMS).

NOTICE

The suggested parameters provided in this section are subject to updates and revisions as a result of product advancements. For the most up-to-date information, please consult the manual provided by the battery manufacturer.

State Definition

To prevent excessive charging or discharging of the battery, three battery statuses have been defined based on different voltage ranges. Please refer to the table below for more details.

SOC definition	Port Voltage / SOC		
	Empty	Normal	Full
By default	SOC < 10%	10%...95%	SOC = 100%

NOTICE

If the battery has remained unused or has not been fully charged for an extended period of time, it is advisable to manually perform a full charge every 15 days. This practice helps to maintain the battery's lifespan and optimal performance.

3.4.1 Charge Management

EPS Charge Management

The purpose of the emergency charge management function is to safeguard the battery against damage resulting from prolonged excessive discharge. During emergency charging, the ESS is unable to respond to discharge commands. The table below outlines the emergency charge conditions for different types of Li-ion batteries.

table 3-1: EPS Charge Management for Li-ion Battery

BMS LED Status	Conditions
Trigger	Either of the following conditions is met: - A battery under-voltage warning is triggered. - An emergency charge command is reported to the inverter.
Finish	All the following conditions are met: - The battery under-voltage warning is cleared. - The emergency charge command reported to the inverter is cleared.

table 3-2 Default SOC Conditions for Li-Lion Battery EPS Charge

SOC definition	Trigger SOC	Finishing SOC
By default	SOC = 0%	SOC > 10%

Normal Charge Management

During normal operation, when the battery voltage is within the acceptable range, the inverter is capable of charging the battery if the PV power exceeds the load power. It ensures that the battery is not overcharged. The maximum charge current is restricted to the lower value between the following:

- The maximum charge current specified by the inverter (100A).
- The maximum/recommended charge current recommended by the battery manufacturer.

As a result, the battery charge power may not reach the nominal power level.

3.4.2 Discharge Management

Discharge Management

Discharge management is implemented to prevent deep discharging of the battery, ensuring its protection. The maximum allowable discharge current is limited to the lower value between the following:

- The maximum discharge current specified by the inverter (100A).
- The maximum/recommended discharge current recommended by the battery manufacturer.

As a result, the battery discharge power may not reach the nominal power level.

4 Unpacking and Storage

4.1 Unpacking and Inspection

The product undergoes comprehensive testing and rigorous inspection prior to shipment. However, there is still a possibility of damage occurring during transit. Therefore, it is essential to conduct a thorough inspection upon receiving the product. Please follow these steps:

- Examine the packaging case for any visible signs of damage.
- Verify the contents of the delivery to ensure completeness, referring to the packing list.
- After unpacking, carefully inspect the inner contents for any signs of damage.

If any damage or incompleteness is detected, promptly contact us or the transport company. It is advisable to provide photographs of the damage to facilitate the resolution process. It is important not to discard the original packaging case. When decommissioning the product, it is recommended to store it in the original packaging case for safekeeping.

NOTICE

Upon receiving the product, it is important to conduct a thorough inspection to ensure its integrity and avoid any potential damage. Please follow these steps:

- Examine the appearance and structural parts of the device for any signs of damage.
- Verify that the contents of the package match the items listed on the packing list. Ensure that you have received the correct product.
- If any issues or discrepancies are found during the inspection, refrain from installing the device and immediately contact your distributor for assistance. If the problem persists or your distributor is unable to resolve the issue, promptly reach out to us for further support.

When unpacking the product, exercise caution to avoid causing any damage, especially if using tools. Take care to handle the product with care and ensure that no unintentional harm is inflicted upon it.

4.2 Scope of Delivery

Hybrid Inverter:

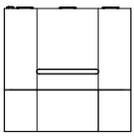
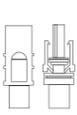
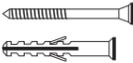
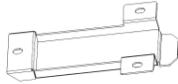
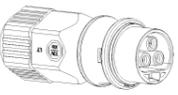
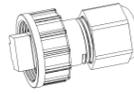
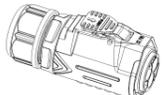
				
A	B	C	D	E
				
F	G	H	I	J
				
K	L	M	N	O
				
P	Q	R	S	T

Item	Name	Quantity
A	Hybrid Inverter	1
B	PV connectors	2+2
C	Mounting screws	4
D	Manual	1
E	WIFI Stick	1
F	Communication Connector	1
G	Mounting brackets	1
H	AC Connector	1
I	OT Terminal	1
J	GRID Connector	1
K	Communication Connector	2
L	Fixed Part	1
M	Fixed Connection Sheet	1
N	LOAD Connector	1
O	M4 combination screw	6
P	M4 Flat-head screws	2
Q	Inverter communication line	1
R	pin	2

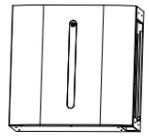
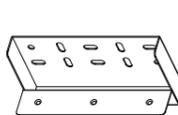
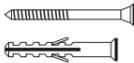
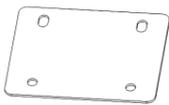
				
A	B	C	D	E
				
F	G	H	I	

Item	Name	Quantity
A	Battery Module	1
B	Battery Cable B+/B	2
C	Top Bracket	1
D	Mounting screws	4
E	M4 Flat-head screws	3
F	Base	1
G	Fixed Connection Sheet	2
H	Parallel communication line	1
I	IM4 combination screw	6

4.3 Product Storage

To ensure the proper storage of the ESS Product when it is not immediately installed, please adhere to the following guidelines:

- Store the ESS Product in its original packing case, ensuring the desiccant is kept inside.
- Maintain a storage temperature between -30°C and +70°C at all times.
- Maintain a storage relative humidity between 0% and 95%, ensuring it is non-condensing.
- If stacking storage is necessary, ensure that the number of stacking layers does not exceed the limit indicated on the outer side of the packing case.
- Keep the packing case upright during storage.
- If the ESS Product needs to be transported again, ensure it is properly packed before loading and transporting.
- Avoid storing the product in areas susceptible to direct sunlight, rain, or strong electric fields.
- Avoid placing the product near items that may affect or damage it.
- Store the product in a clean and dry location to prevent dust and water vapor from causing erosion.
- Avoid storing the product in areas with corrosive substances or at risk of being accessed by rodents and insects.
- Conduct periodic inspections, at least once every six months.
- If any signs of insect or rodent bites are detected, promptly replace the packaging materials.
- If the product has been stored for more than a year, it is necessary to have it inspected and tested by professionals before putting it into operation.

NOTICE

It is crucial to store the ESS in accordance with the specified storage requirements. Failure to meet these requirements may result in product damage, and it's important to note that such damage caused by improper storage is not covered by the warranty. To ensure the safekeeping of the ESS and maintain warranty coverage, please adhere to the storage guidelines provided.

5 Mechanical Mounting

WARNING

Respect all local standards and requirements during mechanical installation.

5.1 Safety during Mounting

DANGER

Make sure there is no electrical connection before installation. Before drilling, avoid the water and electricity wiring in the wall.

WARNING

The performance of the system can be affected by an inadequate installation environment. To optimize system performance, please consider the following:

- Install the ESS in a well-ventilated area to promote proper airflow and heat dissipation.
- Ensure that the heat dissipation system or vents of the ESS are not obstructed by objects or debris.
- Avoid installing the ESS in environments where flammable or explosive materials are present, as well as areas prone to smoke accumulation.

CAUTION

Improper handling may cause personal injury!

- When moving the ESS, be aware of its weight and keep the balance to prevent it from tilting or falling.
- Wear proper protective equipment before performing operations on the ESS.
- The bottom terminals and interfaces of the ESS cannot directly contact the ground or other supports. The ESS cannot be directly placed on the ground

By following these guidelines, you can help maintain an optimal installation environment and ensure the reliable performance of the ESS.

5.2 Location Requirements

To ensure safe operation, long service life, and expected performance, it is important to select an optimal mounting location for the ESS. Consider the following guidelines:

- The ESS, if it has a protection rating of IP65, can be installed both indoors and outdoors, providing flexibility in choosing the mounting location.
- Install the ESS in a location that allows for easy electrical connection, operation, and maintenance. This will facilitate access to the ESS for any necessary maintenance or troubleshooting tasks.

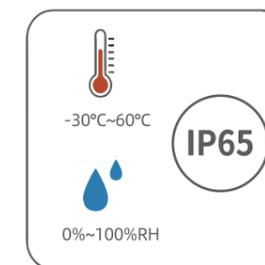

5.2.1 Environment Requirements

- Ensure an installation environment free from flammable or explosive materials.
- Choose a location that is not accessible to children to ensure their safety.
- Ensure that the ambient temperature and relative humidity of the installation site meet the specified requirements.
- To prolong the service life of the ESS, avoid direct exposure to sunlight, rain, and snow. Consider installing them in sheltered areas to provide protection from these elements.

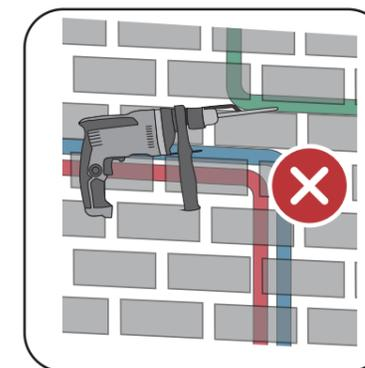

- Ensure proper ventilation for the ESS with adequate air circulation.
- Due to operational noise, it is not recommended to install the ESS in living areas.

5.2.1 Environment Requirements

The mounting structure for the ESS must adhere to local/national standards and guidelines. The installation surface should be sufficiently sturdy to support four times the weight of the ESS and be suitable for its dimensions (e.g., cement walls, plasterboard walls, etc.).

5.2.3 Angle Requirements

The ESS should be installed in a vertical position. It should never be installed horizontally, tilted forward or backward, or upside down.

5.2.4 Clearance Requirements

Allow ample clearance around the ESS to ensure proper heat dissipation. Install the ESS at a suitable height for convenient viewing of the LED indicator and easy access to the operating switch(es).

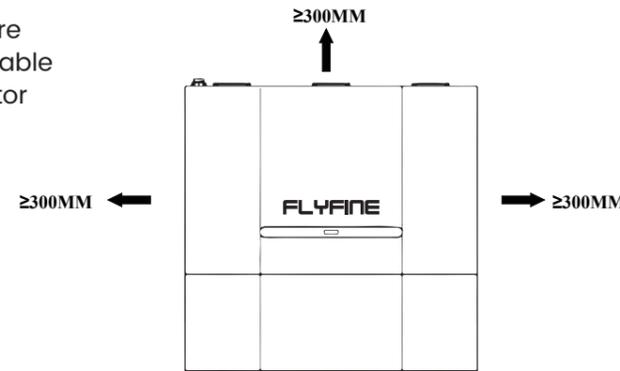

5.3 Installation Tools

Installation tools include but are not limited to the following recommended ones. If necessary, use other auxiliary tools on site.



5.4 Moving the ESS

When transferring the ESS to the installation location, please adhere to the subsequent guidelines:

- Maintain constant awareness of the ESS's weight.
- Employ the handles situated on both sides of the ESS to lift it.
- Mobilize the ESS with the assistance of one or two individuals or with the aid of an appropriate transportation device.
- Ensure that the equipment is securely fastened before releasing it.

CAUTION

Please exercise caution to prevent personal injuries while handling the ESS. Adhere to the following guidelines:

- Ensure an adequate number of personnel are assigned to carry the ESS based on its weight, and installation personnel should wear appropriate protective gear like impact-resistant shoes and gloves.
- Take note of the ESS's center of gravity to prevent tilting during handling.
- Avoid placing the ESS directly on a hard surface, as it may damage the metal enclosure. Instead, use protective materials such as a sponge pad or foam cushion underneath the ESS.
- When moving the ESS hold it by the designated handles and avoid gripping the terminals for transportation.

5.5 Installing the ESS

Note:

This ESS should be installed battery modules first on the bottom and then inverter module on the top.

- **Step 1:** Open the cardboard box to remove the battery module and inspect the accessories. Open the sidepanel for easy handling and remove the upper and lower outlet baffles.

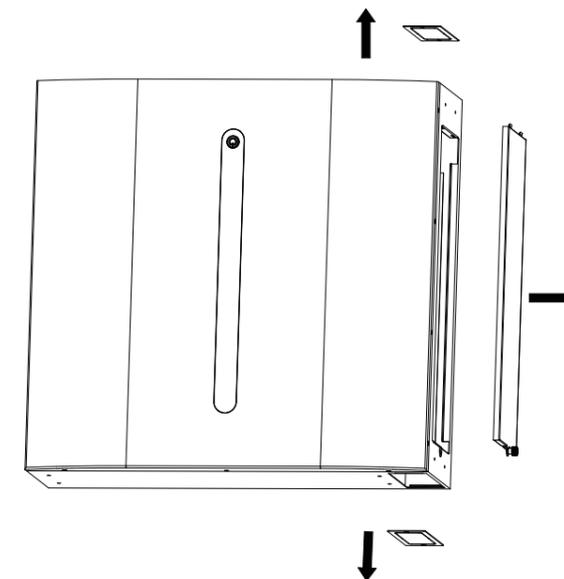

- **Step 2:** Lay the battery pack flat, connect the base to the battery pack with 4 screws.

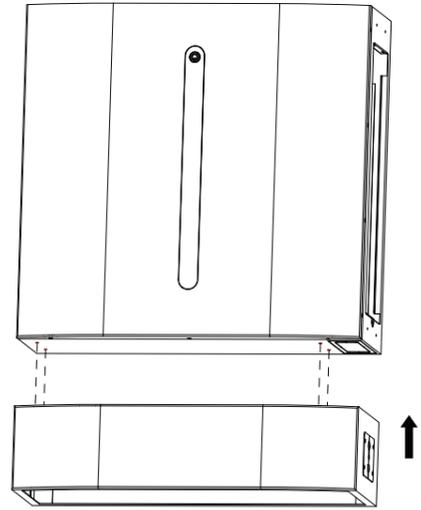

- **Step 3:** As shown in the figure, secure the top bracket of the battery module with three flat head screws.

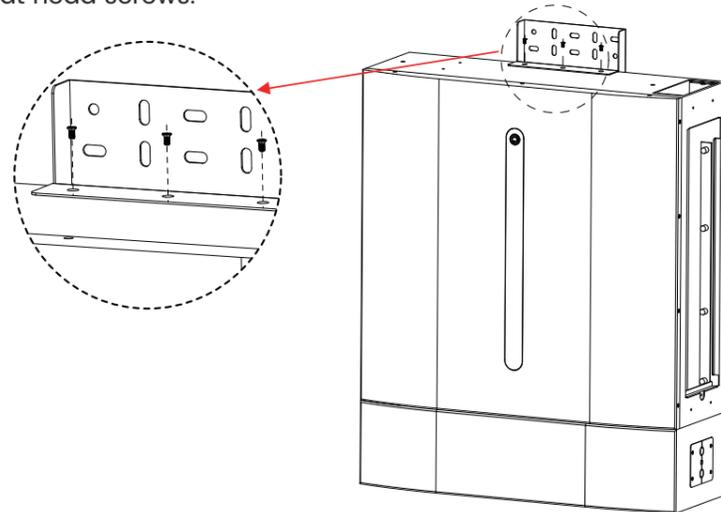

- **Step 4:** Place the battery module against a wall that is perpendicular to the ground. Use an impact drill to drill holes with a diameter of 8mm according to the hole position of the hanger, insert rubber plugs and lock M8 screws. As shown in the figure:

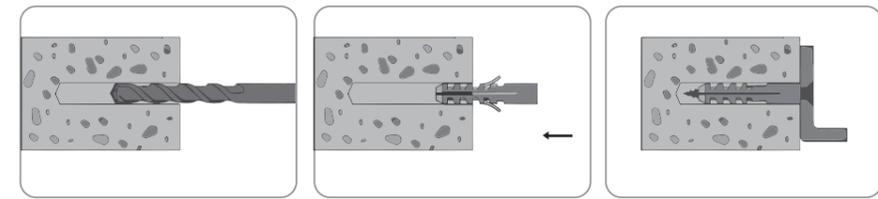
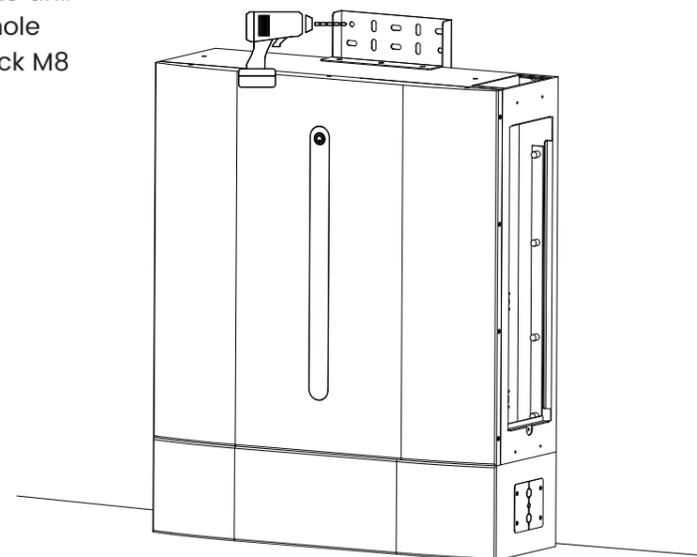

- **Step 5:** Similarly, fix the battery module 2 fixing bracket with M4 screws. Simultaneously install the accessories shown in the diagram (if purchasing a 10KWH energy storage system, step 3 requires the installation of the accessories shown in the diagram)

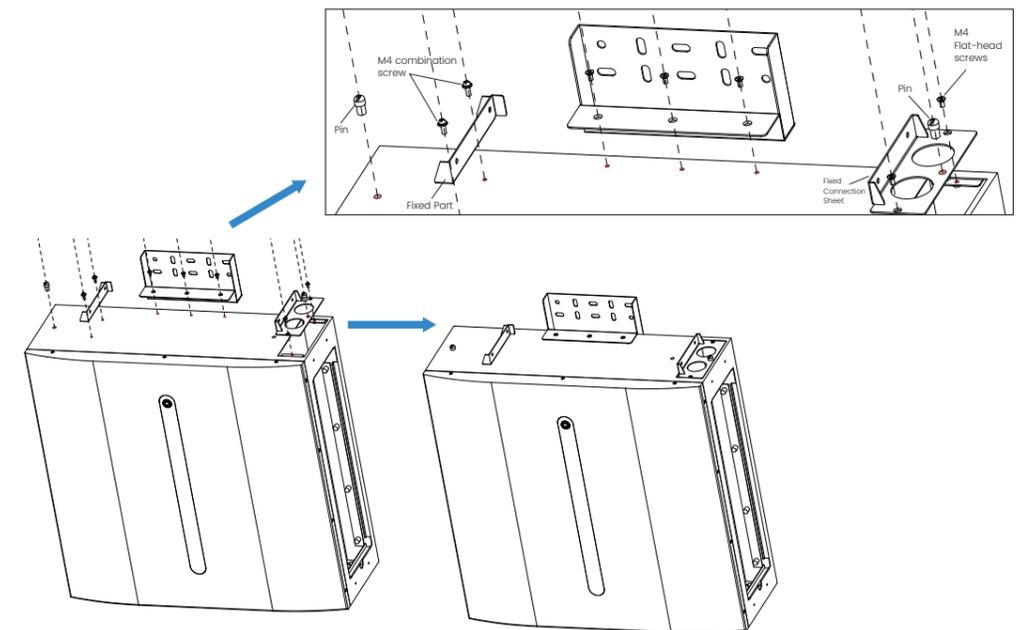

- **Step 6:** Place battery module 2 on battery module 1 as shown in the figure, and secure battery module 1 and battery module 2 with a connecting piece.

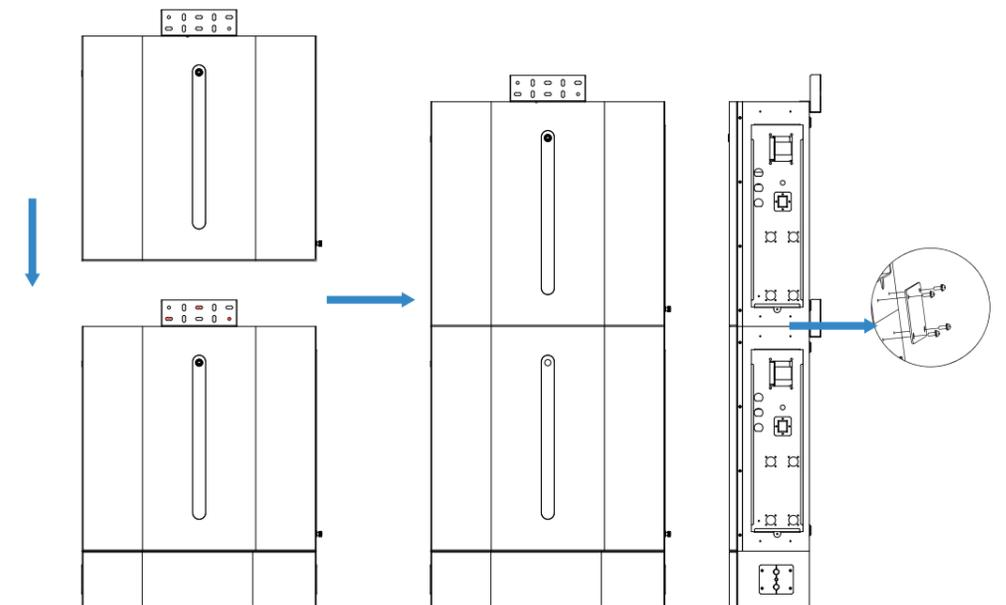

- **Step 7:** Install the inverter bracket according to the position shown in the diagram and secure it with screws. Install the inverter onto the top of the module 2 battery by pressing the positioning bracket position.

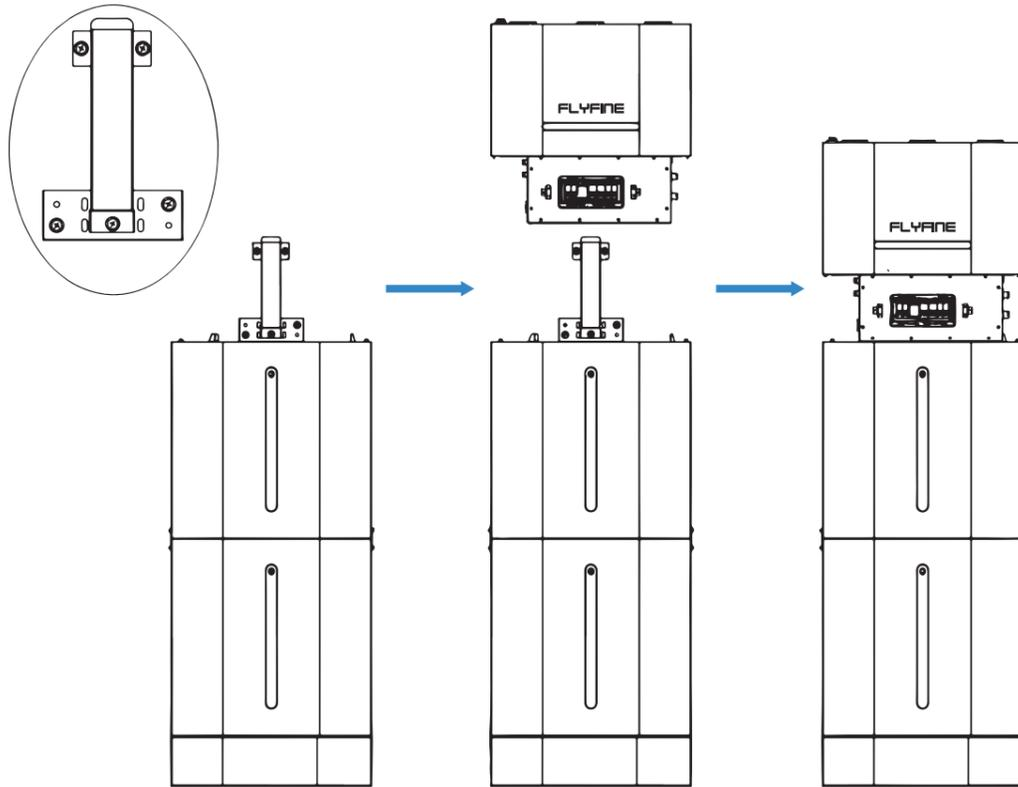

- **Step 8:** Fix the inverter and battery module 2 with screws on both sides, as shown in the figure:

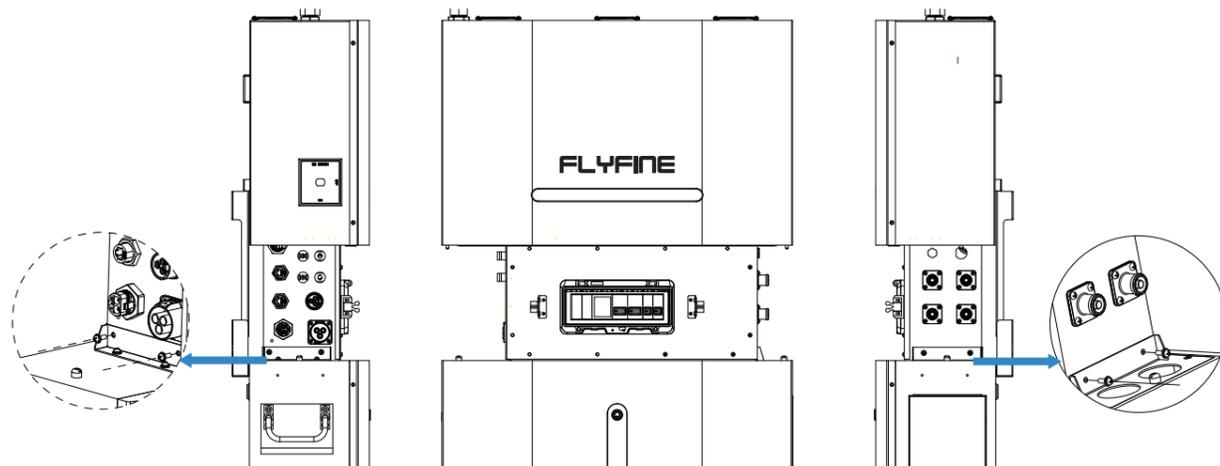

6 Electrical Connection

6.1 Safety Instructions

DANGER

The PV string produces extremely high voltage when exposed to sunlight, which can be lethal. Operators must wear appropriate personal protective equipment during electrical connections. Before touching any DC cables, ensure that they are voltage-free using a measuring instrument. Follow all safety instructions provided in the relevant documents regarding PV strings.

DANGER

- Prior to electrical connections, ensure that the ESS switch and all switches connected to the ESS are set to the "OFF" position to avoid the risk of electric shock.
- Verify that the ESS is undamaged and all cables are voltage-free before performing any electrical work.
- Do not close the AC circuit breaker until the electrical connection is complete.

WARNING

Product damage resulting from incorrect wiring is not covered by the warranty.

- Electrical connections should only be carried out by professionals.
- Operators must wear proper personal protective equipment during electrical connections.
- All cables used in the PV generation system must be securely attached, adequately insulated, and correctly sized.

NOTICE

All electrical connections must adhere to local and national/regional electrical standards.

- Cables used by the user must comply with the requirements of local laws and regulations.
- Connection of the ESS to the grid requires permission from the national/regional grid department.

NOTICE

- All unused terminals must be covered with waterproof covers to maintain the protection rating.
- After completing the wiring, seal the cable inlet and outlet holes with fireproof/waterproof materials such as fireproof mud to prevent the entry of foreign matter or moisture, which may affect the long-term operation of the ESS.
- Adhere to the safety instructions related to PV strings and the regulations concerning the utility grid.

Note:

1. The cable colors shown in the figures in this manual are for reference only. Select cables according to the local cable standards.
2. Before connecting all wires, be sure that side covers of inverter and battery modules are removed. This step should be executed before modules are installed to the wall.

6.2 The battery module connects to the inverter

6.2.1 Preparation

Before connecting the module to the module, it is necessary to check whether the battery module is in a shutdown state. Parallel operation cannot be performed while the module is turned on.

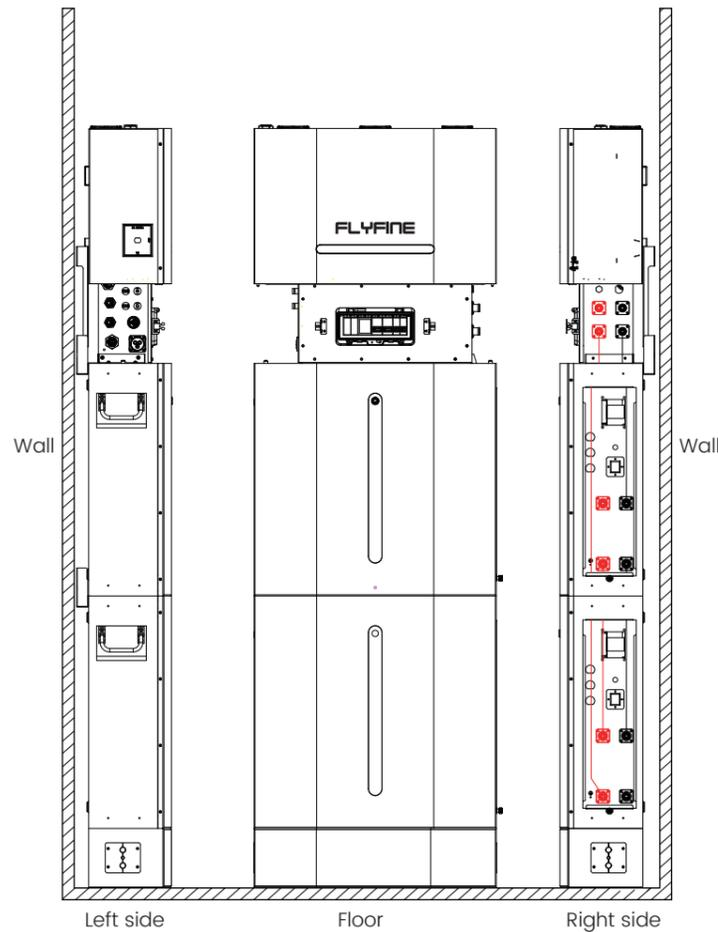

6.3 Utility Grid Connection

6.3.1. Preparation

Before connecting to AC utility, please install a separate AC circuit breaker between surge protection device (SPD) and AC utility. This will ensure the ESS can be securely disconnected during maintenance and fully protected from over current of AC input.

NOTICE

The overvoltage category of the AC input is III. It should be connected to the power distribution.

WARNING

For safety and efficiency, it's very important to use appropriate cables for grid (utility) connection. To reduce risk of injury, please use the proper cable size recommended below.

Suggested cable requirement for AC wire

Nominal Grid Voltage	230VAC
Conductor cross-section (mm ²)	6
AWG no.	10

6.3.2 Connecting to the AC Utility

• **Step 1:** equipment ground.

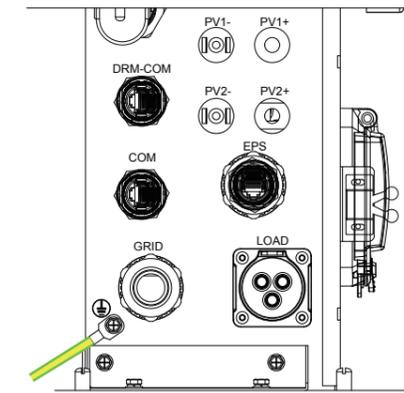
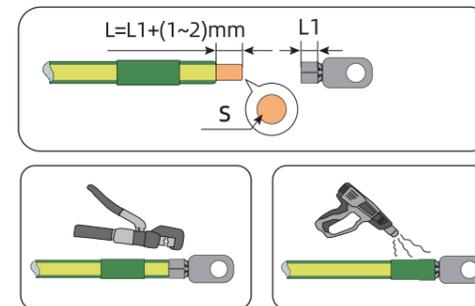

• **Step 2:** Check the grid voltage and frequency with an AC voltmeter to see if it's same as the "VAC" value on the product label.

• **Step 3:** Turn off the circuit breaker.

• **Step 4:** Remove insulation sleeve 10 mm from three conductors and shorten phase L and neutral conductor N for 3 mm.

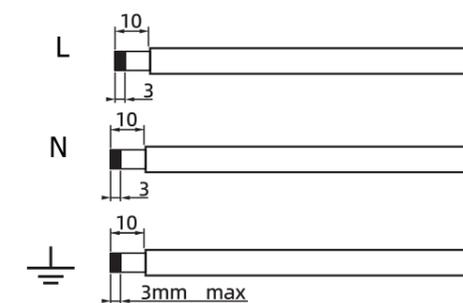

• **Step 5:** Connect wires according to the polarities indicating on terminal block. Be sure to connect PE protective conductor (G) first.

- L→LINE (brown or black)
- N→Neutral (blue or white)
- G→Ground (yellow-green)

- **Step 6:** Make sure the wires are securely connected. The reference tightening torque is 0.6N.m

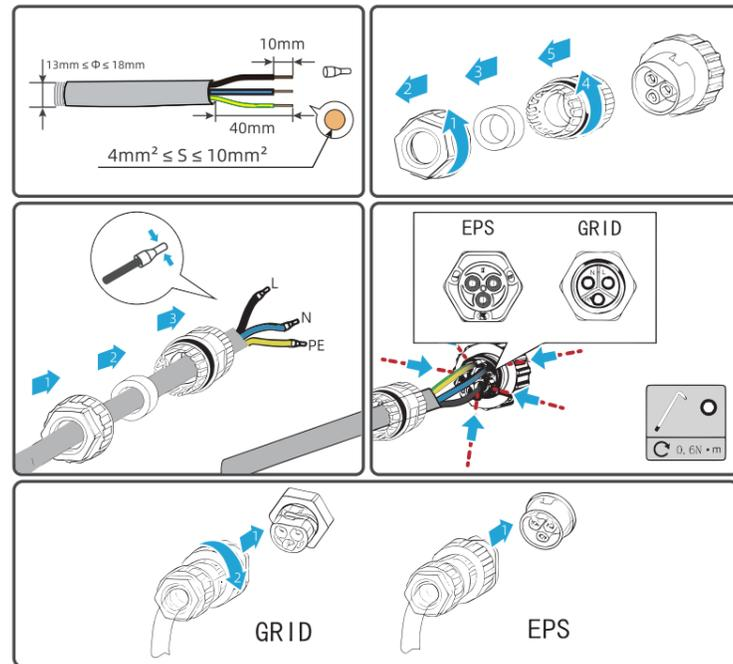

- **Step 7:** If the mixed load power is large, press 8 AWG line. After the cable is locked, fasten the connector shell and tighten the pressure screws. Align the installed LOAD connector with the LOAD port and plug it in to ensure that it is not loose.

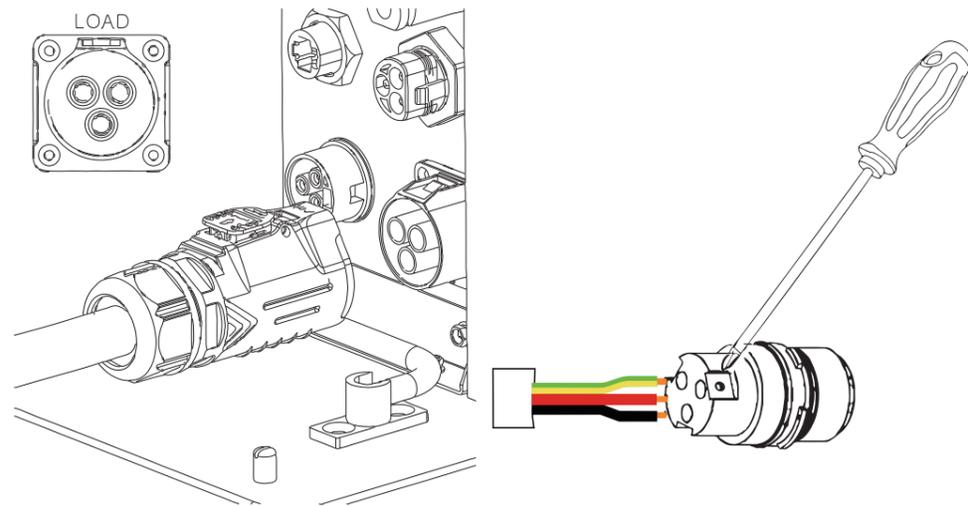

6.4 PV Module (DC) Connection

NOTICE

1. Before connecting to PV modules, please install separately DC circuit breakers between ESS and PV modules.
2. Please use 750VDC/30A circuit breaker.
3. The over-voltage category of the PV input is II.

Please follow the steps below to implement PV module connection:

WARNING

1. Because this ESS is non-isolated, only three types of PV modules are acceptable:

- single crystalline
- poly crystalline with class A-rated
- CIGS modules

*To avoid any malfunction, do not connect any PV modules with possible current leakage to the inverter. For example, grounded PV modules will cause current leakage to the inverter. When using CIGS modules, please be sure NO grounding.

2. It's requested to use PV junction box with surge protection. Otherwise, it will cause damage on inverter when lightning occurs on PV modules.

- **Step 1:** Check the input voltage of PV array modules. The acceptable input voltage of the ESS is 360VDC-600VDC (with rated load). This system is applied with two strings of PV array. Please make sure that the maximum current load of each PV input connector is 16A.

NOTICE

Exceeding the maximum input voltage can destroy the unit!!
Check the system before wire connection.

- **Step 2:** Disconnect the circuit breaker and switch off the DC switch.
- **Step 3:** Assemble provided PV connectors with PV modules by the following steps.

Components for PV connectors and Tools:

Female connector housing	
Female terminal	
Male connector housing	
Male terminal	
Crimping tool and spanner	

Prepare the cable and follow the connector assembly process:

Strip one cable 8 mm on both end sides and be careful NOT to nick conductors.

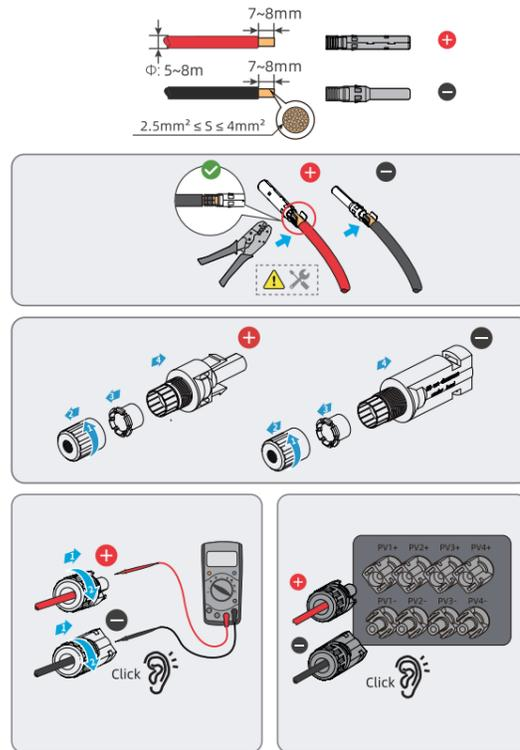

• **Step 4:** Check the correctness of the polarity of connection cable on PV modules and PV input connectors. Then, connect positive pole (+) of connection cable to positive pole (+) of PV input connector. Connect negative pole (-) of connection cable to negative pole (-) of PV input connector.

WARNING

For safety and efficiency, it's very important to use appropriate cables for PV module connection. To reduce risk of injury, please use the proper cable size as recommended below.

Conductor cross-section (mm2)	AWG no.
4~6	10~12

Note:
Never directly touch the terminals of ESS. It might cause lethal electric shock.

• **Step 5:** ESS Communication Function:

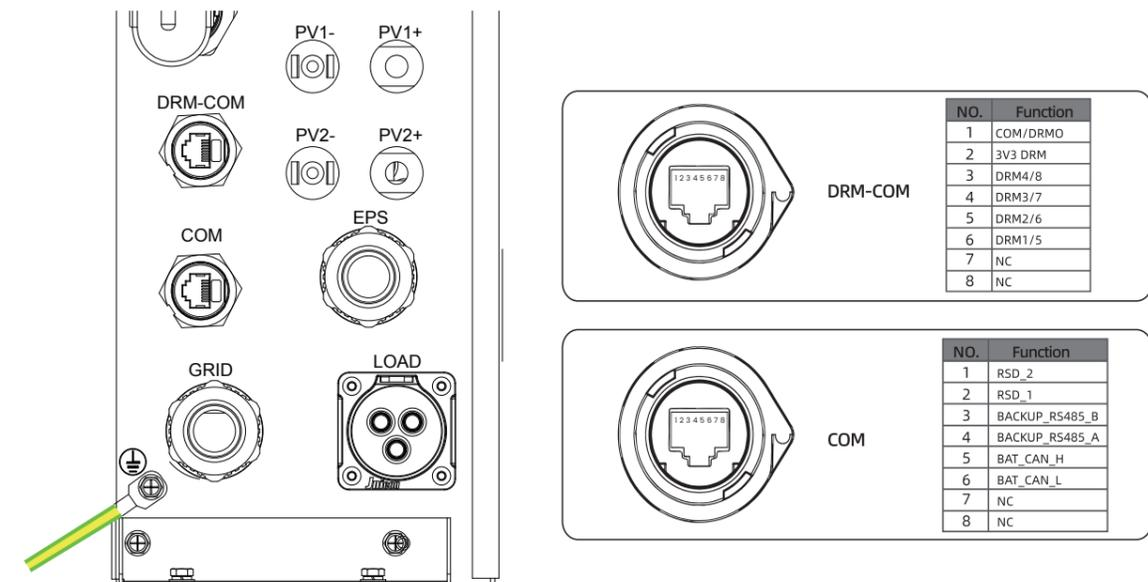

Battery communication definition

	RS485B interface	RS485-8P8C			
		RJ45 Pin	Definition Description	RJ45 Pin	Definition Description
Parallel communication		1	RS485A_B	5	NC
		2	RS485A_A	6	NC
		3	NC	7	RS485A_A
		4	NC	8	RS485A_B
Communication with host computer		1	RS485B_B	5	NC
		2	RS485B_A	6	NC
		3	NC	7	RS485B_A
		4	NC	8	RS485B_B
External communication		CAN-8P8C			
		RJ45 Pin	Definition Description	RJ45 Pin	Definition Description
		1	RS485A_B	5	CAN_L
		2	RS485A_A	6	NC
3	NC	7	RS485A_A		
4	CAN_H	8	RS485A_B		

7 Commissioning

7.1 Inspection before Commissioning

Before starting the ESS, please ensure the following checklist items are checked:

- Confirm that all equipment has been installed securely and in accordance with the manufacturer's instructions.
- Verify that the DC switch(es) and AC circuit breaker are in the "OFF" position.
- Ensure that the ground cable is properly and securely connected.
- Check that the AC cable is correctly and reliably connected.
- Verify that the DC cable is properly and securely connected.
- Confirm that the communication cable is properly and securely connected.
- Seal any vacant terminals to prevent dust or moisture ingress.
- Ensure that no foreign items, such as tools, are left on top of the machine or inside the junction box (if applicable).
- Verify that the AC circuit breaker is selected according to the requirements specified in the manual and local standards.
- Check that all warning signs and labels on the ESS are intact and legible.

It is essential to complete these checks before starting the ESS to ensure safe and reliable operation.

7.2 Powering on the System

If all the checklist items have been verified and meet the requirements, follow these steps to start up the ESS for the first time:

- Step 1: Turn on the AC circuit breaker located between the ESS and the grid.
- Step 2: Rotate the DC switch to the "ON" position.
- Step 3: If the irradiation and grid conditions meet the requirements, the ESS will start operating normally. Observe the LED indicator on the ESS to ensure it is functioning properly. Refer to the "2.1 LED Panel" section of the manual for an introduction to the LED screen and its indicator definitions.
- Step 4: If using the SOLARMAN Smart system, refer to the quick guide for its indicator definitions. By following these steps, you can safely start up the ESS and begin its normal operation.

7.3 Download App

If you are a residential user, please scan the QR code provided below to download the SOLARMAN Smart app. Alternatively, you can visit the website <https://home.solarmanpv.com> to access the app.



SOLARMAN Smart

7.4 Registration

Go to SOLARMAN Smart and sign up.

Click on "Sign up" and create your account here. Please note that use an email address to register for an account.

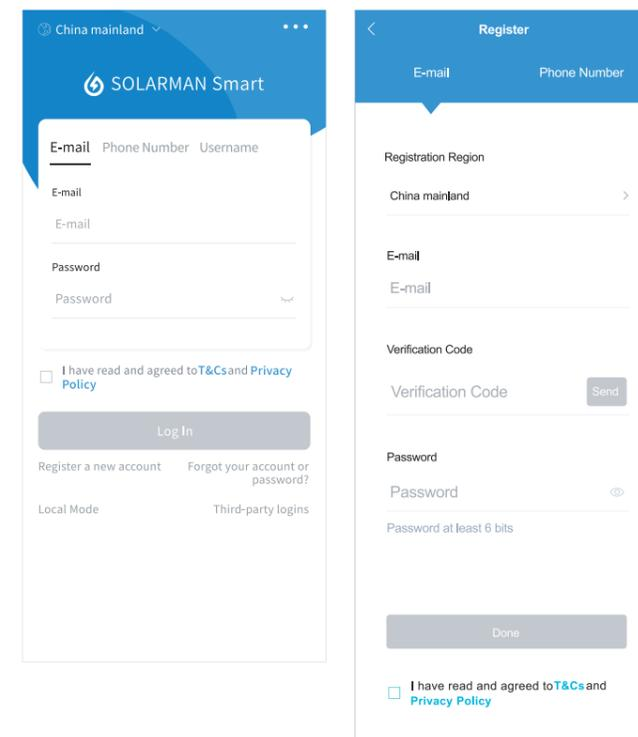

7.5 Create a Plant

Click "Add Now" to create your solar installation.

Please provide the necessary information about your solar plant, including basic details and any additional relevant information.

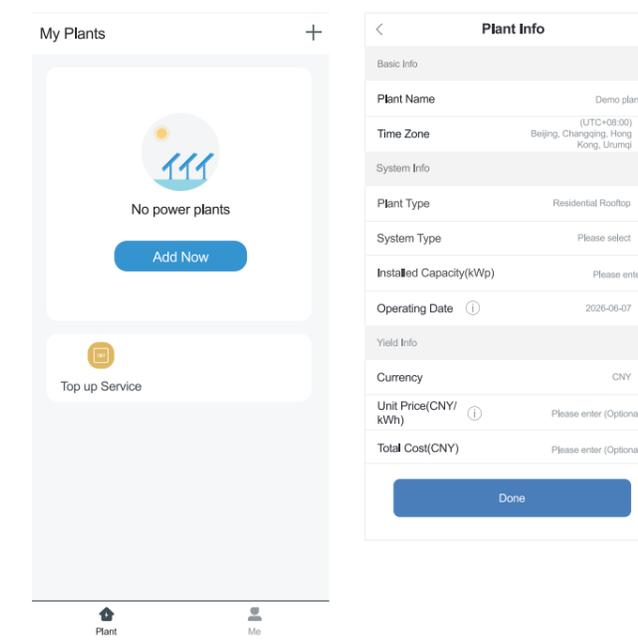

7.6 Add a Logger

- **step 1:** Manually enter the serial number (SN) of the logger.
- **step 2:** Click on the icon located on the right side and scan the barcode to enter the logger serial number. You can locate the logger serial number on the external packaging or on the body of the logger itself.

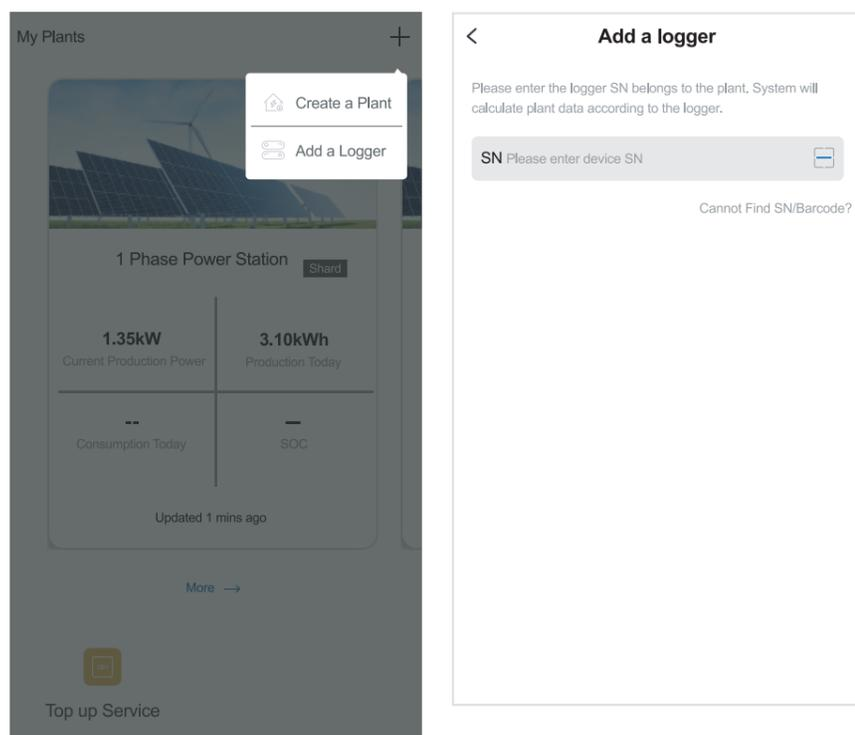

7.7 Network Configuration

- **step 1:** Click on "Go to Configure" to access the network settings. (Ensure that Bluetooth and WiFi are turned ON.)

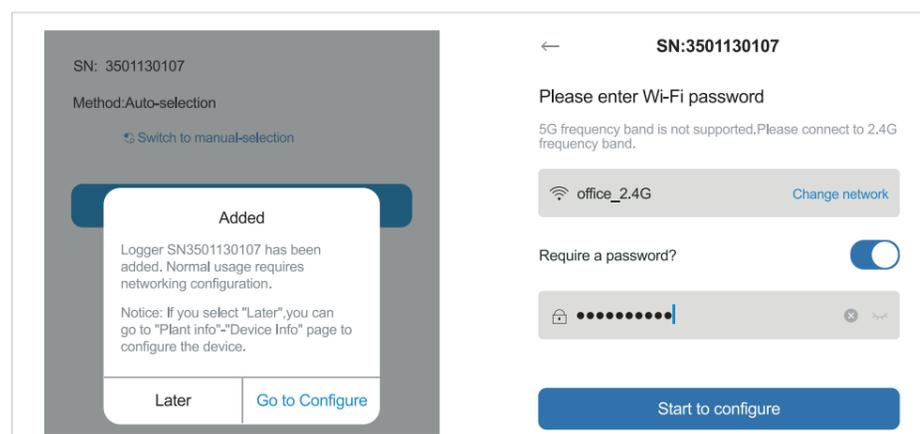

- **step 2:** Please wait for a few minutes. Afterward, click on "Done" to complete the setup and view the plant data.

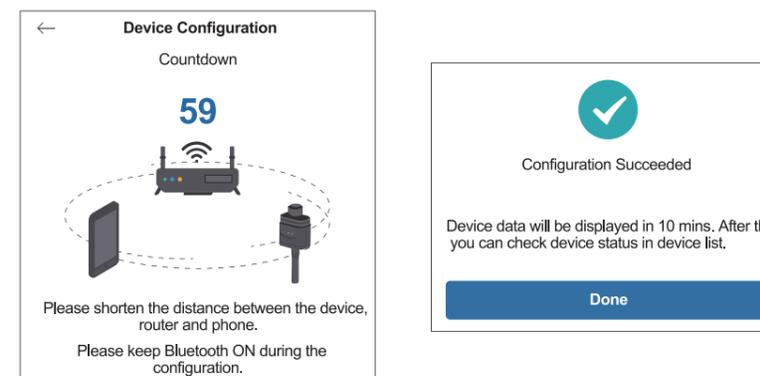

Notice:
5G WiFi is not supported.

If the configuration process fails, please check the following reasons and attempt the setup again:

1. Ensure that WLAN (Wireless Local Area Network) is turned on.
2. Verify that your WiFi connection is functioning properly.
3. Confirm that the wireless router does not have any restrictions in place, such as a white-black list.
4. Remove any special characters from the Wi-Fi network name (SSID) or password.
5. Reduce the distance between your phone and the device during the configuration process.
6. Try connecting to a different Wi-Fi network if available.

Warning: Before leaving the site, it is crucial to ensure that the stick logger is functioning correctly. If you notice any abnormal behavior or issues, please refrain from leaving the site and immediately contact customer service. You can reach customer service at the following number: 400-181-0512

7.8 Stick Logger Installation

Assemble the logger to the ESS communication interface according to the diagram provided.

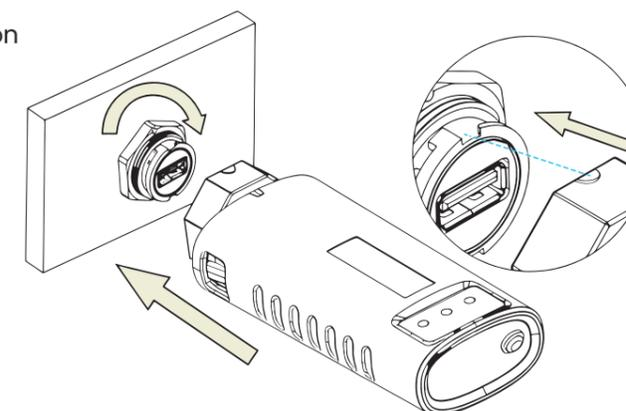

7.9 Logger Status

7.9.1 Check Indicator light

Lights	Implication	Status Description (All lights are single green lights.)
NET	Communication with router	1. Light off: Connection to the router failed. 2. On 1s/Off 1s (Slow flash): Connection to the router succeeded. 3. Light keeps on: Connection to the server succeeded. 4. On 100ms/Off 100ms (Fast flash): Distributing network fast.
COM	Communication with inverter	1. Light keeps on: Logger connected to the inverter. 2. Light off: Connection to the inverter failed. 3. On 1s/Off 1s (Slow flash): Communicating with inverter.
READY	Logger running status	1. Light off: Running abnormally. 2. On 1s/Off 1s (Slow flash): Running normally. 3. On 100ms/Off 100ms (Fast flash): Restore factory settings.

When the router is connected to the network normally, the stick logger should exhibit the following normal operation status:

1. Connection to the server succeeded: The NET light will remain illuminated after the logger is powered on.
2. Logger running normally: The READY light will flash intermittently.
3. Connection to the ESS succeeded: The COM light will remain illuminated.

7.10 Abnormal State Processing

If you encounter abnormal data on the platform while the stick logger is running, please refer to the following table and use the status of the indicator lights to perform basic troubleshooting. If the issue persists or if the indicator lights' status is not listed in the table, please contact Customer Support for assistance.

(Note: Use the table below after the stick logger has been powered on for at least 2 minutes.)

NET	COM	READY	Fault Description	Fault Cause	Solution
Any state	OFF	Slow flash	Communicate with inverter abnormally	1. Connection between stick logger and inverter loosen. 2. Inverter does not match with stick logger's communication rate.	1. Check the connection between stick logger and inverter. Remove the stick inverter, logger and install again. 2. Check inverter's communication rate to see if it matches with stick logger's. 3. Long press Reset button for 5s, reboot stick logger.
OFF	ON	Slow flash	Connection between logger and router abnormal	1. Stick logger does not have a network. 2. Router WiFi signal strength weak.	1. Check if the wireless network configured. 2. Enhance router WiFi signal strength.
Slow flash	ON	Slow flash	Connection between logger and router normal, connection between logger and remote server abnormal	1. Router networking abnormal. 2. The server point of logger is modified. 3. Network limitation, server cannot be connected.	1. Check if the router has access to the network. 2. Check the router's setting, if the connection is limited. 3. Contact our customer service.
OFF	OFF	OFF	Power supply abnormal	1. Connection between stick logger and inverter loosen or abnormal. 2. Inverter power insufficient. 3. Stick Logger abnormal.	1. Check the connection, remove the stick logger and install again. 2. Check inverter output power. 3. Contact our customer service.
Fast flash	Any state	Any state	Networking status	Normal	1. Exit automatically after 2mins. 2. Long press Reset button for 5s, reboot stick logger. 3. Long press Reset button for 10s, restore factory settings.
Any state	Any state	Fast flash	Restore factory settings	Normal	1. Exit automatically after 1mins. 2. Long press Reset button for 5s, reboot stick logger. 3. Long press Reset button for 10s, restore factory settings.



8 System Decommissioning

8.1 Disconnecting the ESS

8.1.1 Disconnecting the ESS

CAUTION

To ensure safety and prevent the risk of burns, it is important to follow proper procedures when operating or performing maintenance on the ESS. Please adhere to the following steps to disconnect the ESS from the AC and DC power sources:

Step 1: Disconnect the external AC circuit breaker that supplies power to the ESS. Make sure to secure it against accidental reconnection.

Step 2: Rotate the DC switch to the "OFF" position to disconnect all PV string inputs from the ESS.

Step 3: Wait for approximately 10 minutes to allow the capacitors inside the ESS to completely discharge. This step is crucial to ensure that no residual electrical charge remains.

Step 4: Use a current clamp to verify that the DC cable is free from any electrical current. This is an important safety measure to prevent any potential shocks or hazards.

Please remember to wear protective gloves when operating the ESS, even after it has been shut down and allowed to cool down. In addition, always follow safety guidelines and refer to the manufacturer's instructions for specific procedures and precautions related to maintenance and service work on the ESS.

8.1.2 Dismantling the ESS

CAUTION

Risk of burn injuries and electric shock!
Do not come into contact with any internal live components until at least 10 minutes have elapsed after disconnecting the ESS from the utility grid and PV input.

Before disassembling the ESS, ensure that both AC and DC connections are disconnected.

- Step 1:** Disconnect all cables from the ESS in reverse order as described in the "Electrical Connection" section.
- Step 2:** Disassemble the ESS following the reverse steps outlined in the "Mechanical Mounting" section.
- Step 3:** If needed, remove the wall-mounting bracket from the wall.
- Step 4:** If the ESS will be stored for future use, please refer to the "ESS Storage" section for proper conservation guidelines.

8.1.3 Disposal of the ESS

Users are solely responsible for the proper disposal of the ESS.

WARNING

Please ensure that the ESS is disposed of in accordance with the relevant local regulations and standards to prevent any property losses or casualties.

NOTICE

Certain components of the ESS may pose a risk of environmental pollution. Please adhere to the disposal regulations for electronic waste that are applicable at your installation site when disposing of these components.

8.2 Decommissioning the Battery

To decommission a Li-ion battery after the ESS has been decommissioned, follow these steps:

- Step 1:** Disconnect the DC circuit breaker located between the battery and the ESS.
- Step 2:** Disconnect the communication cable that connects the battery to the ESS.
- Step 3:** Wait for approximately 1 minute to allow for any residual voltage to dissipate. Then, use a multimeter to measure the voltage at the battery ports
- Step 4:** If the battery port voltage is zero, proceed to disconnect the power cables from the battery module.

Note: It is important to exercise caution and follow proper safety procedures when handling and decommissioning batteries.

CAUTION

We do not assume liability for the disposal of the battery. The responsibility for proper battery disposal rests with the user. Please ensure that the battery is disposed of in accordance with applicable local regulations and standards to avoid any property damage or harm.

9 Appendix

9.1 Technical Data

Model	FBA10240	FAB20480
PV Input (DC)		
Recommend max.PV input power	10000Wp	11000Wp
Max. PV Voltage	600V	
Min. operation/Start-up Voltage	40V / 50V	
Rated Pv Input Voltage	360V	
No.of Independent MPPT Inputs/strings	2/1	
Input/Output(AC)		
Max. AC Input Powerfrom Grid	10000VA	11000VA
Rated AC Output Power	5000W	6000W
Max. AC Output Power	5000w	6000w
Rated AC Voltage	220V/230V/240V	
AC Voltage Range	154V ~ 276V	
Rated Grid Frequency	50Hz/60Hz	
Grid Type	Single phase	
Efficiency		
Max. Efficiency	97.5%	97.7%
European Efficiency	97.0%	97.3%
Protection & Function		
Protection	DC reverse polarity/ AC short circuit/ leakage/battery input reverse polarity	
Surge Protection	DC type II / AC type II	
DC swith(PV) /DC fuse[battery]	YES	
Battery input reverse polarity protection	YES	
General Data		
Dimensions(W*H*D)	600*365*180 mm	
Weight	≤20kg	
Degree of Protection	Ip65	
Operating Ambient Temperature Range	-25°C ~ 60°C, 0 ~ 100%	
Max. Operating Altitude	4000m	
Rated Output Power for Backup Load	6000W	
Backup Data(off-grid model)		
Rated Voltage	220V/230V/240V(±2%)	
Frequency Range	50Hz / 60Hz(±0.5%)	
Rated Output Power	5000W/5000VA	5000W/6000VA
Peak Output Power	8400VA,10S	
Product Specifications(BAT&SYSTEM)		
Nominal DC Voltage	51.2V	
Battery Capacity	200Ah	400Ah(200Ah*2)
Energy(Kwh)	10.24Kwh	20.48Kwh
Maximum Discharging Current	100A	
Cycle Life	6500Cycles (80%DOD)	
Certification	UN38.3,MSDS,CE-EMC,IEC62619,UL1973	
System General Data		
Temperature Range	-20°C ~ 60°C	
Environment Humidity	0 ~ 95%	
Dimensions(H*W*D)mm	1300*620*212	1895*620*212
Net weight (kg)	120KG	220KG
Communication Method	WIFI/4G	
Grid connection Certification	CE-LVD,CE-EMC,EN50549-1/CEI-021,VDE4105/0124,G99,IEC61727/62116/61683:NA/EEA-NE7-CH2020:	