

A Leading Energy Solution
Manufacturer Vendor

FLYFINE

User Manual
**Hybrid
Solar Inverter**

- 8kW Inverter ◦
- 10kW Inverter ◦
- 14kW Inverter ◦
- 16kW Inverter ◦

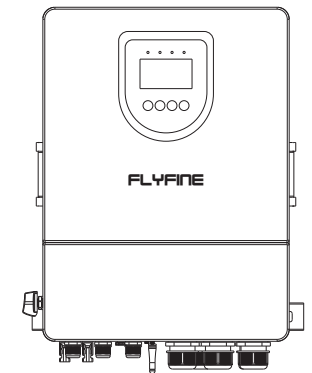

 Flyfine Digital Energy Co., Ltd.

 +86-18924268899

 Sales@flyfinetech.com

 www.flyfinebattery.com



www.flyfinebattery.com



TABLE OF CONTENTS

1. ABOUT THIS MANUAL 03

 1.1 Purpose 03

 1.2 Scope 03

2. SAFETY INSTRUCTIONS 03

3. INTRODUCTION 04

 3.1 Features 04

 3.2 Basic System Architecture 05

 3.3 Product Overview 06

4. INSTALLATION 08

 4.1 Unpacking And Inspection 08

 4.2 Preparation 08

 4.3 Mounting The Unit 08

 4.4 Battery Connection 10

 4.5 AC Input/Output Connection 12

 4.6 PV Connection 14

 4.7 Current Transformer Connection 17

 4.8 Final Assembly 19

 4.9 Communication Connection 20

 4.10 Dry Contact Signa 21

5. OPERATION 22

 5.1 Power ON/OFF 22

 5.2 Operation And Display Panel 22

 5.3 LCD Display Icons 23

 5.4 LCD operation flow chart 25

 5.5 LCD Display Setting 25

 5.5.1 Detail Page 25

 5.5.2 System Setting Page 27

 5.5.3 Battery Setting Page 27

 5.5.4 Detail Page 30

 5.5.5 Time Of Use Page 32

 5.5.6 Grid Setting Page 32

 5.5.7 Basic Setting Page 33

 5.5.8 History Error Page 34

 5.6 Fault Reference Code 34

 5.7 Warning Indicator 35

6. SPECIFICATIONS 36

 Table 1 Line Mode Specifications 36

 Table 2 Inverter Mode Specifications 36

 Table 3 Two Load Output Power 37

 Table 4 Charge Mode Specifications 37

 Table 5 Grid-Tie Operation 38

 Table 6 General Specifications 38

7. TROUBLE SHOOTING 39

***APPENDIX I: PARALLEL FUNCTION**

- 1. INTRODUCTION** 40
- 2. MOUNTING THE UNIT** 40
- 3. WIRING CONNECTION** 40
- 4. PARALLEL CONNECTION** 41
 - 4.1 Parallel Operation in Single phase 41
 - 4.2 Support 3-phase equipment 44
- 5. PV CONNECTION** 45
- 6. LCD SETTING AND DISPLAY** 45
- 7. COMMISSIONING** 46
 - 7.1 Parallel in single phase 46
 - 7.2 Support three-phase equipment 46
- 8. TROUBLE SHOOTING** 48

***APPENDIX II: Wi-Fi CONNECTION INSTRUCTIONS**

- 1. WIRELESS WI-FI DISTRIBUTION NETWORK** 49
 - 1.1 APP Download 49
 - 1.2 Registered Account 49
- 2. SUPPORTING NETWORK AND ADDING DEVICE** 49
 - 2.1 Wi-Fi collector connection Router 49
 - 2.2 Add Device 50
- 3. COLLECTOR FAULT DIAGNOSE AND INDICATOR LIGHT JUDGMENT** 52
 - 3.1 Collector Fault Diagnose 52
 - 3.2 Collector Indicator Status 52

1.ABOUT THIS MANUAL

1.1 Purpose

This manual describes the assembly, installation, operation and troubleshooting of this unit. Please read this manual carefully before installations and operations, Keep this manual for future reference.

1.2 Scope

This manual provides safety and installation guidelines as well as information on tools and wiring.

2.SAFETY INSTRUCTIONS

WARNING

- This chapter contains important safety and operating instructions. Read and keep this manual for future reference.
- Only qualified service persons are able to service this device. If errors still persist after following troubleshooting table, please send this inverter/charger back to local dealer or service center for maintenance.
- Because this inverter is non-isolated, only three types of PV modules are acceptable: single crystalline, poly crystalline with class A-rated and CIGS modules. To avoid any malfunction, do not connect any PV modules with possible current leakage to the inverter. For example, grounded PV modules will cause current leakage to the inverter, When using CIGS modules, please be sure no grounding.

CAUTION

- To reduce risk of injury, charge only deep-cycle lead acid type rechargeable batteries and LiFePO4 batteries. Other types of batteries may burst, causing personal injury and damage.
- Only qualified personnel can install this device with battery.
- Never charge a frozen battery.
- It's required to use PV junction box with surge protection. Otherwise, it will caused damage on inverter when lightning occurs on PV modules.

1. Before using the unit, read all instructions and cautionary markings on the unit, the batteries and all appropriate sections of this manual.
2. Do not disassemble the unit. Take it to a qualified service center when service or repair is required. Incorrect reassembly may result in a risk of electric shock or fire.
3. To reduce risk of electric shock, disconnect all wirings before attempting any maintenance or cleaning. Turning off the unit will not reduce this risk.
4. For optimum operation of this inverter/charger, please follow required spec to select appropriate cable size. It's very important to correctly operate this inverter/charger.
5. Be very cautious when working with metal tools on or around batteries. A potential risk exists to drop a tool to spark or short circuit batteries or other electrical parts and could cause an explosion.
6. Please strictly follow installation procedure when you want to disconnect AC or DC terminals. Please refer to installation section of this manual for the details.
7. One piece of 400A fuse is provided as over-current protection for the battery supply.
8. This inverter/charger should be connected to a permanent grounded wiring system. Be sure to comply with local requirements and regulation to install this inverter.
9. Never cause AC output and DC input short circuited. Do not connect to the mains when DC input short circuits.

3. INTRODUCTION

This is a multi-function inverter/charger, combining functions of inverter, solar charger and battery charger to offer uninterruptible power support with portable size. Its comprehensive LCD display offers user-configurable and easy-accessible button operation such as battery charging current, AC/solar charger priority, and acceptable input voltage based on different applications.

3.1 Features

1. Pure sine wave inverter.
2. Configurable input voltage range for home appliances and personal computers via LCD setting.
3. Configurable battery charging current based on applications via LCD setting.
4. Configurable AC/Solar Charger priority via LCD setting.
5. Compatible to mains voltage or generator power.
6. Auto restart while AC is recovering.
7. Overload/ Over temperature/ short circuit protection.
8. Smart battery charger design for optimized battery performance.
9. Cold start function.

- 10.It can realize the simultaneous use of less than six machines.
- 11.Built-in Wi-Fi for mobile monitoring (APP required), can connect and communicate with the lithium battery.
- 12.The allowable charge and discharge time can be set.

3.2 Basic System Architecture

The following illustration shows basic application for this inverter/charger. It also includes following devices to have a complete running system:

- 1.Battery,Generator or Utility.
- 2.PV modules.

Consult with your system integrator for other possible system architectures depending on your requirements.This inverter can power all kinds of appliances in home or office environment, including motor-type appliances such as tube light, fan, refrigerator and air conditioner.

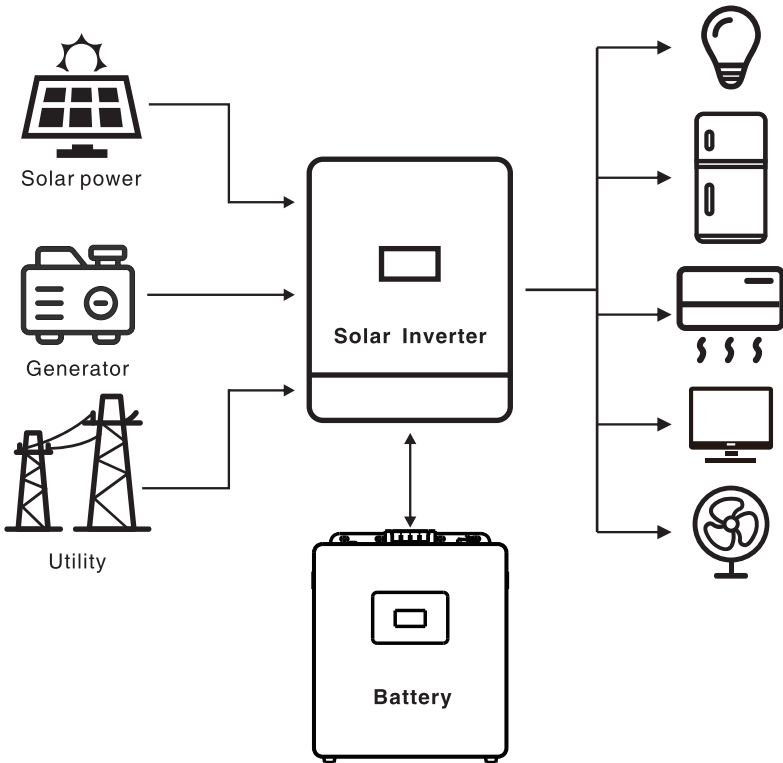

3.3 Product Overview

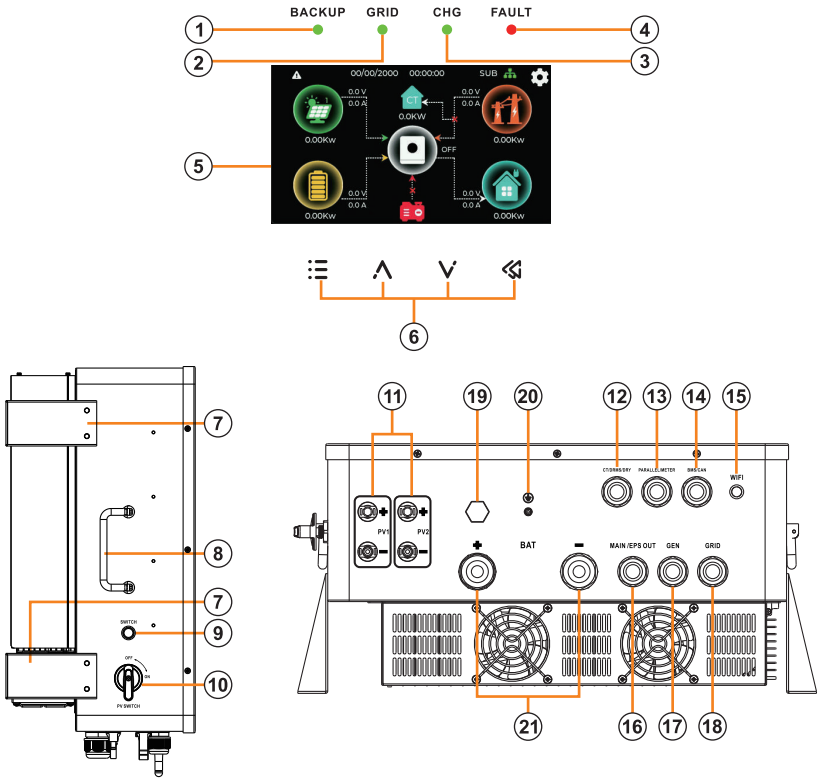

(This diagram is a schematic for 8KW and 10KW)

- | | |
|----------------------------------------------------------------------------------------------------------------------------------------------------------------------------------------------------------------------------------------------------------------------------------------------------------------------------------------------|----------------------------------------------------------------------------------------------------------------------------------------------------------------------------------------------------------------------------------------------------------------------------------------------------------------------------------------------------------|
| <ul style="list-style-type: none"> 1.Back up indicator 2.Grid indicator 3.Charge indicator 4.Fault indicator 5.LCD display 6. Function buttons 7.Wall rack 8.lifting handle 9.Power on/off switch 10.PV switch 11.PV1 and PV2 input | <ul style="list-style-type: none"> 12.Current Transformer/DRMS port/DRY 13.Parallel port/METER port 14.Battery communication/RS-485 port 15.WIFI communication 16.Main/EPG output 17.Generator 18.GRID 19.Vent valve 20.Ground terminal 21.Battery input |
|----------------------------------------------------------------------------------------------------------------------------------------------------------------------------------------------------------------------------------------------------------------------------------------------------------------------------------------------|----------------------------------------------------------------------------------------------------------------------------------------------------------------------------------------------------------------------------------------------------------------------------------------------------------------------------------------------------------|

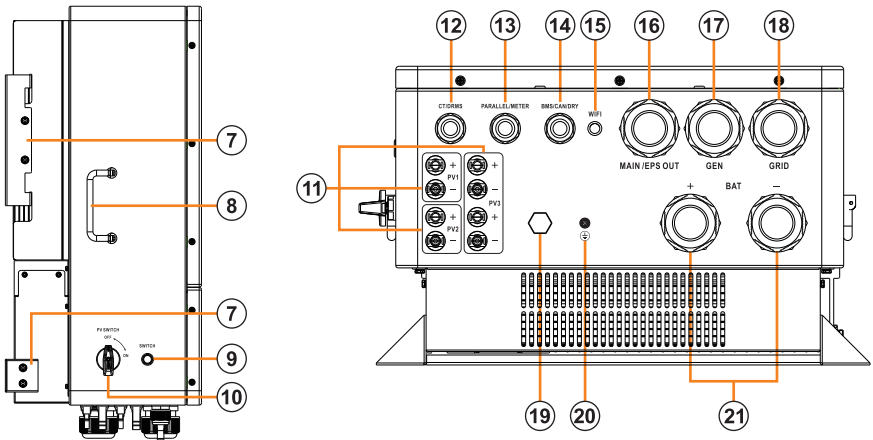
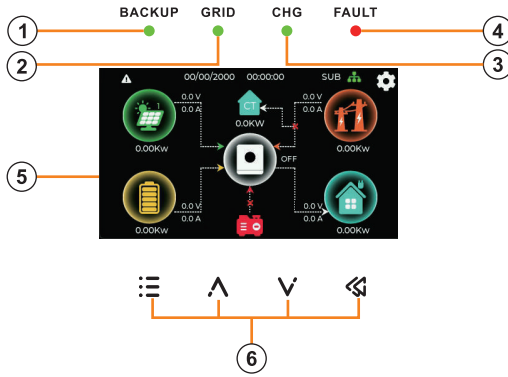

(This diagram is a schematic for 14KW and 16KW)

- 1.Back up indicator
- 2.Grid indicator
- 3.Charge indicator
- 4.Fault indicator
- 5.LCD display
- 6. Function buttons
- 7.Wall rack
- 8.lifting handle
- 9.Power on/off switch
- 10.PV switch
- 11.PV1 PV2 and PV3 input
- 12.Current Transformer/DRMS port
- 13.Parallel port/METER port
- 14.Battery communication/RS-485 port/DRY
- 15.WIFI communication
- 16.Main/EPS output
- 17.Generator
- 18.GRID
- 19.Vent valve
- 20.Ground terminal
- 21.Battery input

4.INSTALLATION

4.1 Unpacking And Inspection

Before installation, please inspect the unit. Be sure that nothing inside the package is damaged. You should have received the following items inside of package:

Parts List for 8KW/10KW		
▶The unit x 1	▶M6 screw x 8	▶Current transformer x1
▶User manual x 1	▶Expansion screw x 4	▶Parallel communication line x 1
▶Wall bracket x 4	▶WIFI antenna x 1	

Parts List for 14KW/16KW		
▶The unit x 1	▶M6 screw x 8	▶Ring terminal x 9
▶User manual x 1	▶Expansion screw x 6	▶Parallel communication line x 1
▶Wall mount x 1	▶WIFI antenna x 1	
▶Wall bracket x 2	▶Current transformer x1	

***NOTE:**

Due to differences in machine models, there may be slight variations in accessories; please refer to the actual items received. In case of any updates to the accessories, no separate notification will be given.

4.2 Preparation

Before connecting all the wires, please first loosen the screws on the wire connection cover and remove the cover.

4.3 Mounting The Unit

Consider the following points before selecting where to install:

- 1.Do not mount the inverter on flammable construction materials.
- 2.Mount on a solid surface.
- 3.Install this inverter at eye level in order to allow the LCD display to be read at all times.
- 4.For proper air circulation to dissipate heat, allow a clearance of approx.20 cm to the side and approx. 50 cm above and below the unit.
- 5.The ambient temperature should be between -10°C and 50°C to ensure optimal operation.
- 6.The recommended installation position is to be adhered to the wall vertically.
- 7.Make sure that other objects and surfaces are left with enough space from the machine to ensure adequate heat dissipation and that there is enough room to remove the wires.

! CAUTION

- Suitable for mounting on concrete or other non-combustible surface only.

Installation steps for 8KW/10KW wall-mounted brackets:

1. First, use 8 M6 screws to install the 4 wall-mounted brackets on the machine.
2. Drill four holes in the wall; the positions are determined according to the positions of the wall-mounted brackets, and the recommended depth is 40~45mm.
3. Secure the machine to the wall via the wall-mounted brackets using 4 expansion screws.

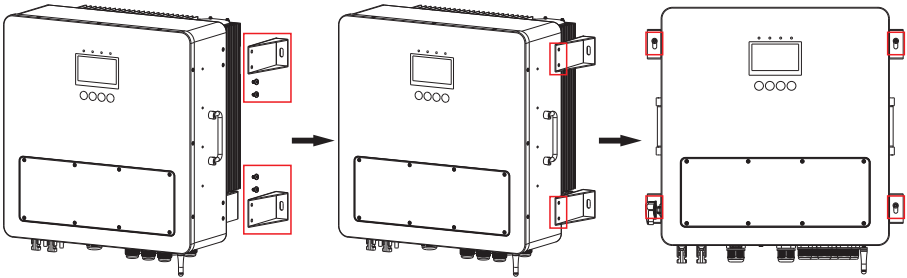

Installation steps for 14KW/16KW wall-mounted brackets:

1. First, use 4 or 6 M8 expansion bolts to secure the large wall bracket to the wall. The recommended drilling depth is 55~60 mm.
2. After securing the wall mount, align the grooves on the side of the machine with the wall mount, hang it onto the mount from top to bottom, and lock both sides of the machine to the wall mount using 4 M6 screws.
3. Fix the two small wall brackets to both sides of the machine using 4 M6 screws. Then secure the two small wall brackets to the wall with 2 M8 expansion bolts. (Users may decide whether to install these two small wall brackets according to their needs. If not required, skip this step.)

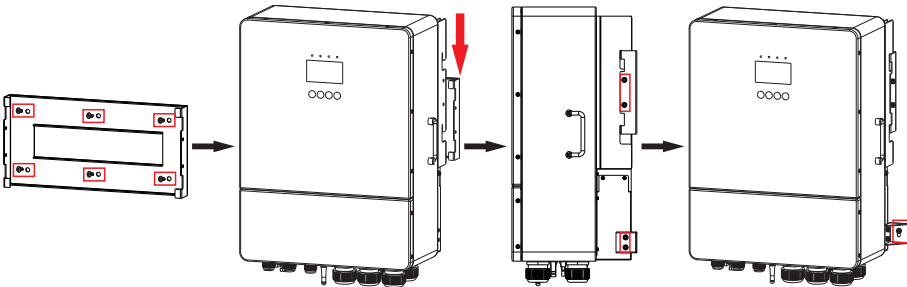

4.4 Battery Connection

⚠ CAUTION

- For safety operation and regulation compliance, it's requested to install a separate DC over-current protector or disconnect device between battery and inverter. It may not be requested to have a disconnect device in some applications, however, it's still requested to have over-current protection installed. Please refer to typical amperage in below table as required fuse or breaker size.

⚠ WARNING

- All wiring must be performed by a qualified personnel.
- It's very important for system safety and efficient operation to use appropriate cable for battery connection. To reduce risk of injury, please use the proper recommended cable as below.

Recommended battery cable size:

Model	Wire size	Cable(mm ²)	Torque value(max)
8KW/10KW	3/0AWG	85.01	18.0N•m
14KW/16KW	2 x 0AWG	53.49	12.5N•m

Please follow below steps to implement battery connection:

- Remove insulation sleeve 18 mm for positive and negative conductors.
- Suggest to put bootlace ferrules on the end of positive and negative wires with a proper crimping tool.

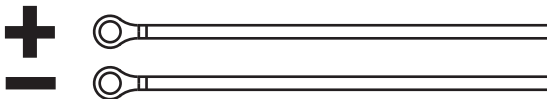

- Connect all battery packs as below chart.

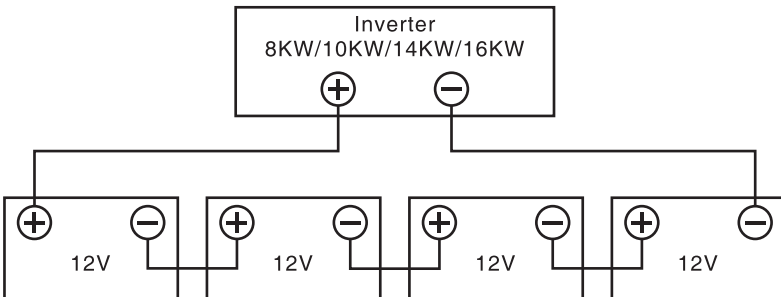

4. Insert the battery wires flatly into battery connectors of inverter and make sure the bolts are tightened with torque. Make sure polarity at both the battery and the inverter is correctly connected and conductors are tightly screwed into the battery terminals. Recommended tool: #2 Pozi Screwdriver

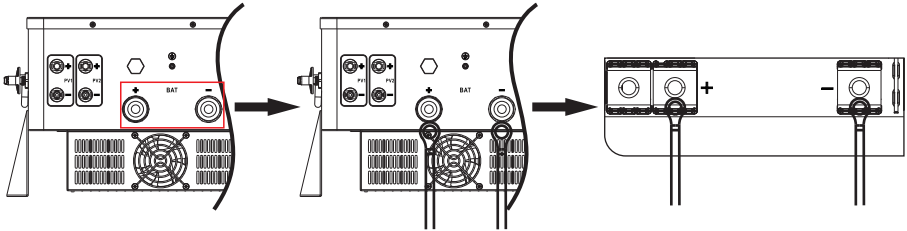

(8KW/10KW Wiring Diagram)

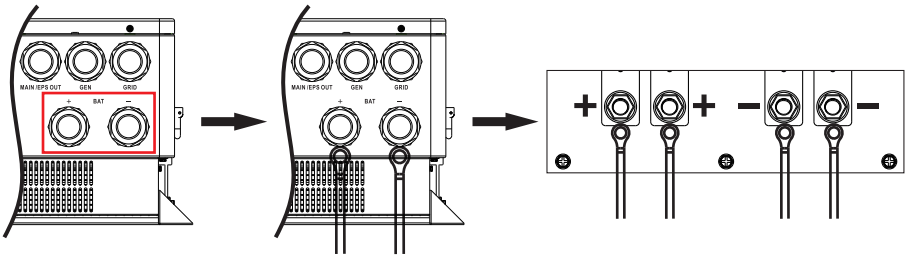

(14KW/16KW Wiring Diagram)

⚠ CAUTION

- Before making the final DC connection or closing DC breaker/disconnector, be sure positive (+) must be connected to positive (+) and negative (-) must be connected to negative (-).

⚠ WARNING

- Installation must be performed with care due to high battery voltage in series.

4.5 AC Input/Output Connection

⚠ CAUTION

- Before connecting to AC input power source, please install a separate AC breaker between inverter and AC input power source. This will ensure the inverter can be securely disconnected during maintenance and fully protected from over current of AC input. The recommended spec of AC breaker is 50A for 8KW,70A for 10KW,90A for 14KW,150A for 16KW.
- There are two terminal blocks with “IN” and “OUT” markings. Please do NOT mis-connect input and output connectors.

⚠ WARNING

- All wiring must be performed by a qualified personnel.
- It's very important for system safety and efficient operation to use appropriate cable for AC input connection. To reduce risk of injury, please use the proper recommended cable size as below.

Suggested cable requirement for AC wires:

Model	Wire size	Cable(mm ²)	Torque value(max)
8KW/10KW	6AWG	13.3	2.5N·m
14KW/16KW	2AWG	33.62	10.0N·m

Please follow below steps to implement AC input/output connection:

- 1.Before making AC input/output connection, be sure to open DC protector or disconnect first.
- 2.Remove insulation sleeve 10mm for six conductors. And shorten phase L and neutral conductor N3 mm.
- 3.Insert AC input wires according to polarities indicated on terminal block and tighten the terminal screws. Be sure to connect PE protective conductor (⊕) first.

- L→LINE(brown or black)
- N→Neutral(blue)
- ⊕→Ground (green&yellow)

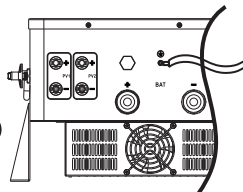

(8KW/10KW Wiring Diagram)

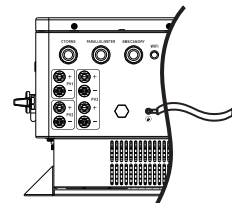

(14KW/16KW Wiring Diagram)

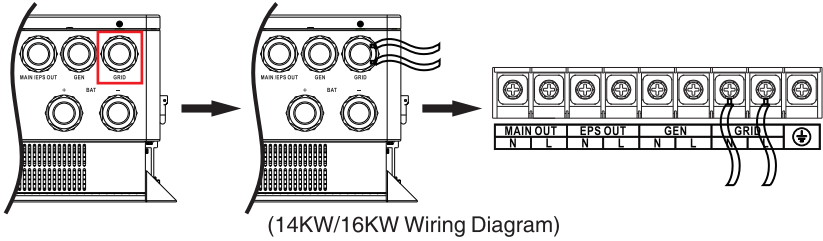
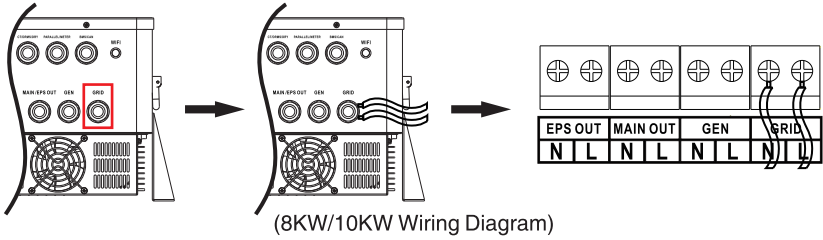

WARNING

- Be sure that AC power source is disconnected before attempting to hardwire it to the unit.

4. Then, insert AC output wires according to polarities indicated on terminal block and tighten terminal screws.

L→LINE(brown or black)

N→Neutral(blue)

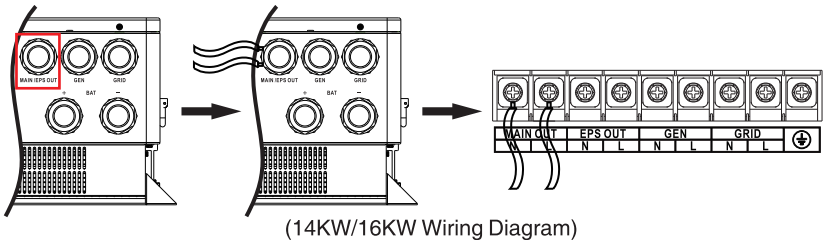
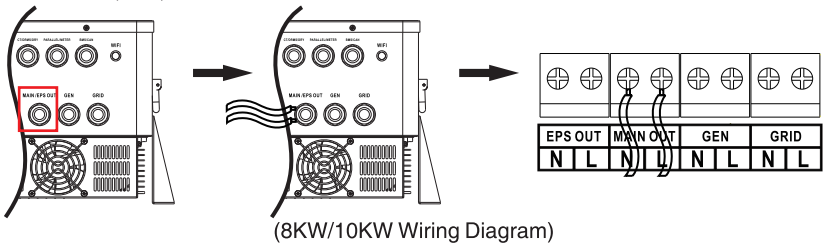

5. Make sure the wires are securely connected.

⚠ CAUTION

- Appliances such as air conditioner are required at least 2~3 minutes to restart because it's required to have enough time to balance refrigerant gas inside of circuits. If a power shortage occurs and recovers in a short time, it will cause damage to your connected appliances. To prevent this kind of damage, please check manufacturer of air conditioner if it's equipped with time-delay function before installation. Otherwise, this inverter/charger will trig overload fault and cut off output to protect your appliance but sometimes it still causes internal damage to the air conditioner.

4.6 PV Connection

⚠ CAUTION

- Before connecting to PV modules, please install separately a DC circuit breaker between inverter and PV modules.
- It's required to use PV junction box with surge protection. Otherwise, it will cause damage on inverter when lightning occurs on PV modules.

⚠ WARNING

- Because this inverter is non-isolated, only three types of PV modules are acceptable: single crystalline and poly crystalline with class A-rated and CIGS modules.
- To avoid any malfunction, do not connect any PV modules with possible current leakage to the inverter. For example, grounded PV modules will cause current leakage to the inverter, When using CIGS modules, please be sure NO grounding.
- It's very important for system safety and efficient operation to use appropriate cable for PV module connection. To reduce risk of injury, please use the proper recommended cable size as below.

Model	Wire size	Cable(mm ²)	Torque value(max)
8KW/10KW/14KW/16KW	1×10AWG	5.27	1.2N•m

PV Module Selection:

When selecting proper PV modules, please be sure to consider below parameters:

- 1.Open circuit Voltage (Voc) of PV modules not exceeds max. PV array open circuit voltage of inverter.
- 2.Open circuit Voltage (Voc) of PV modules should be higher than min. battery voltage.

Inverter Model	8KW/10KW/14KW/16KW
Max. PV Array Open Circuit Voltage	520Vdc
PV Array MPPT Voltage Range	80Vdc~500Vdc

Take 700Wp PV module as an example. After considering above two parameters, the recommended module configurations are listed as below table.

Solar Panel Spec. (reference)	Solar input	Q'ty of panels	Total input power
	(Min in serial: 3 pcs, max. in serial: 9 pcs)		
-700Wp	3 pcs in serial	3 pcs	2100W
-Vmp: 40.5V	7 pcs in serial	7 pcs	4900W
-Imp: 17.29A	9 pcs in serial	9 pcs	6300W
-Voc: 48.6V	7 pieces in serial and 2 sets in parallel	14 pcs	9800W
-Isc: 18.32A	9 pieces in serial and 2 sets in parallel	18 pcs	12600W
-Cells:288(144x2)	7 pieces in serial and 3 sets in parallel	21 pcs	14700W

PV Module Wire Connection

Step 1: Check the input voltage of PV array modules. The acceptable input voltage of the inverter is 80 VDC ~520VDC, Please make sure that the maximum current load for PV1 and PV2 is 18 A, and the maximum current load for PV3 is 36 A.

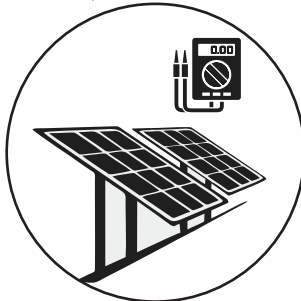





⚠ CAUTION

- Exceeding the maximum input voltage can destroy the unit ! check the system before wire connection.

Step 2: Disconnect the DC circuit breaker.

Step 3: Assemble provided PV connectors with PV modules by the following below steps.

Components for PV connectors and Tools:

Male connector housing		Female terminal	
Male terminal		Crimping tool and spanner	
Female connector housing			

Cable preparation and connector assembly process:

Strip one cable 8 mm on both end sides and be careful NOT to nick conductors.

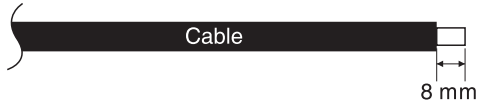

Insert striped cable into male terminal and crimp male terminal as shown below charts.



Insert assembled cable into male connector housing as shown below charts.

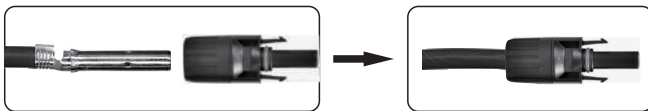

Insert striped cable into female terminal and crimp female terminal as shown below charts.



Insert assembled cable into female connector housing as shown below charts.

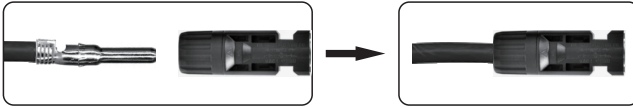

Then, use spanner to screw pressure dome tightly to female connector and male connector.

Step 4: Check correct polarity of connection cable from PV modules and PV input connectors. Then, connect positive pole (+) of connection cable to positive pole (+) of PV input connector, Connect negative pole (-) of connection cable to negative pole (-) of PV input connector.

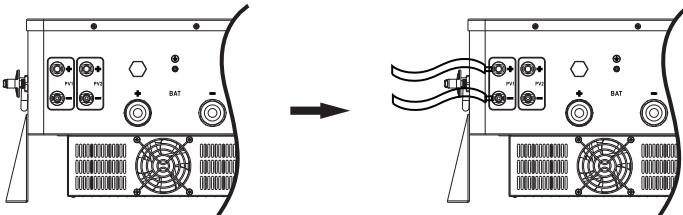

(8KW/10KW Wiring Diagram)

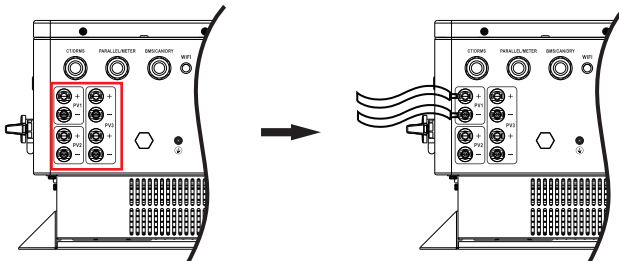

(14KW/16KW Wiring Diagram)

4.7 Current Transformer Connection

Insert the crystal head of the CT sensor into the network port with the CT logo.

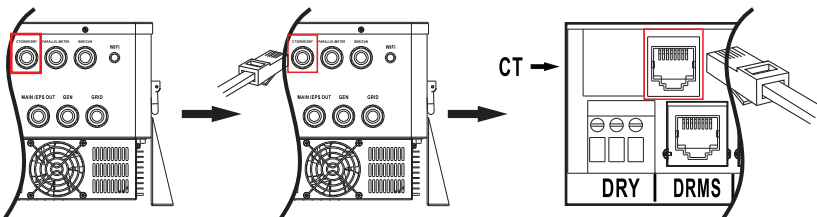

(8KW/10KW Wiring Diagram)

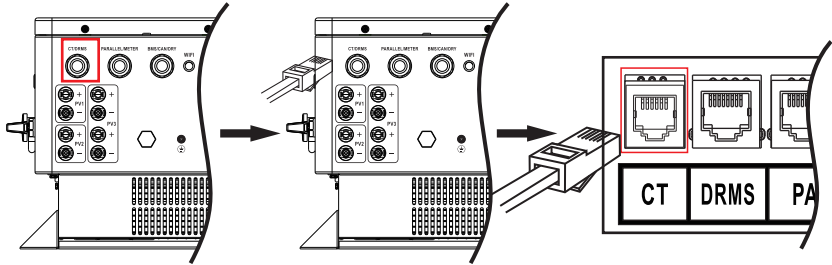

(14KW/16KW Wiring Diagram)

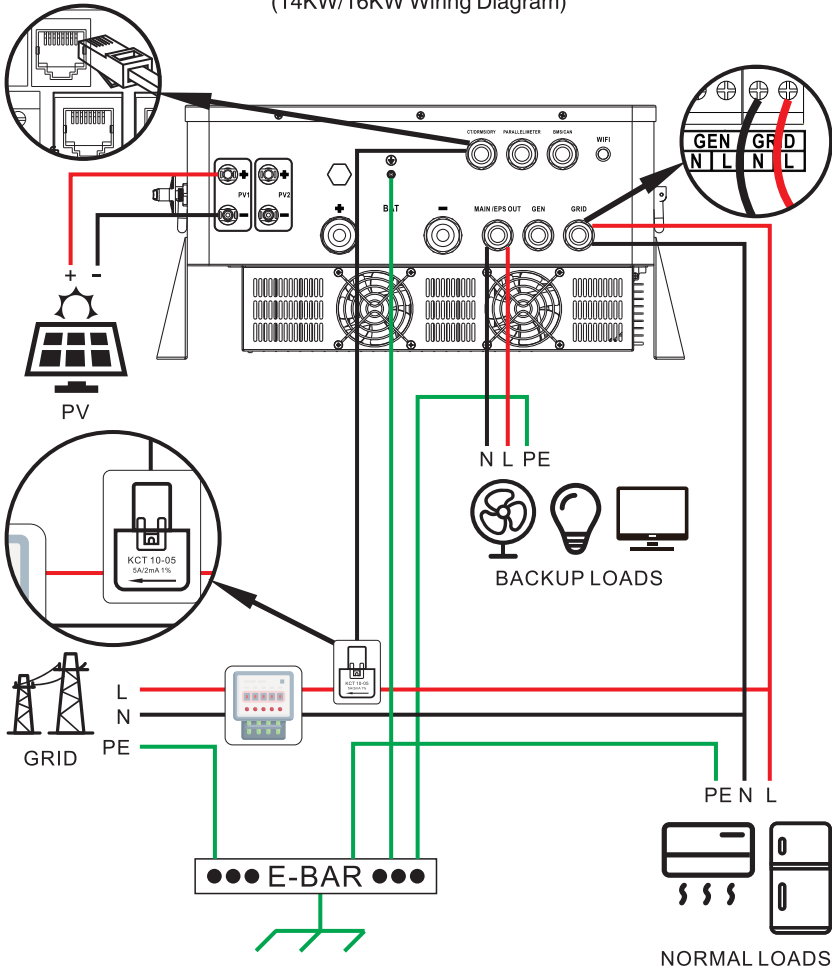

(8KW/10KW Wiring Diagram)

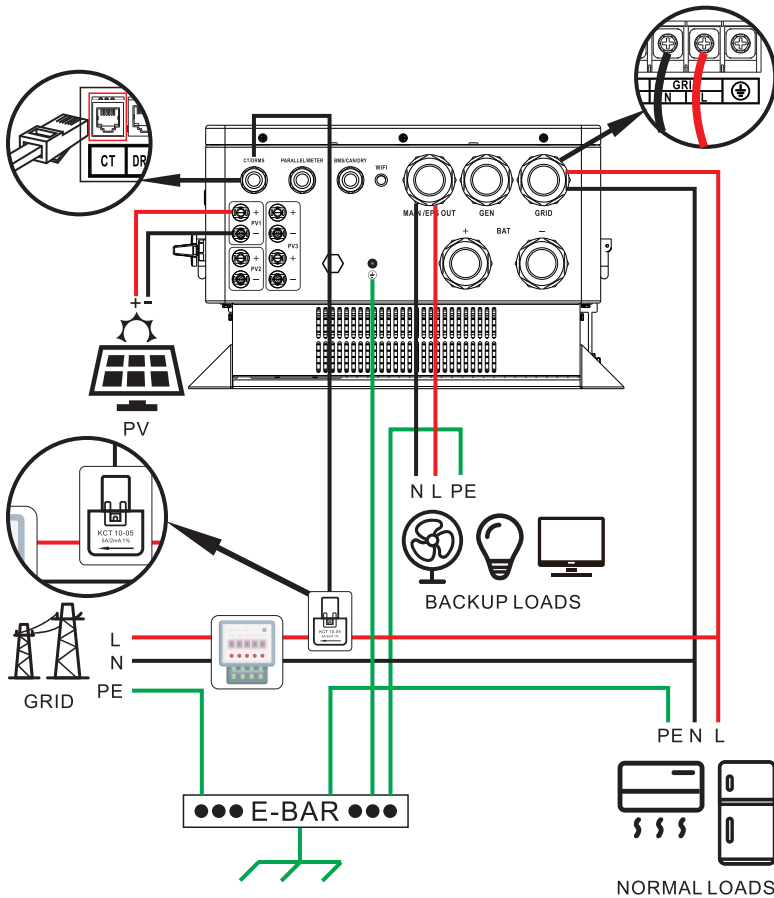

(14KW/16KW Wiring Diagram)

How to determine if the CT is connected in reverse:

When the machine continuously displays the “CT wrong direction” alarm, it indicates an incorrect CT wiring method. In this case, please check the following two items: first, verify whether the CT is connected to the (L) line of the mains power supply; second, check if the direction indicated by the arrow on the CT points to the main power supply.

4.8 Final Assembly

After all the wires are connected, please put the wire connection cover back in place and tighten the screws.

4.9 Communication Connection

1.Wi-Fi cloud communication:

Please screw the Wi-Fi antenna onto the SMA adapter at the bottom of the machine. Download APP and installed from APP store, and refer to “Wi-Fi Plug Quick Installation Guideline” to set up network and registering. The inverter status would be shown by mobile phone APP or webpage of computer.

2.Battery communication

The communication between the battery and the inverter can be realized through the battery communication interface, so that the inverter and the lithium battery can exchange information (Baud rate:9600).

3.Lithium battery and inverter connection:

Use power cables, communication cables for lithium batteries, and inverters to connect.

Note: Lithium battery and inverter positive and negative positions, check the correct installation:The RJ45 connector of the communication cable connects to the BMS port of the inverter, and the other RJ45 connector connects to the RS485 port of the lithium battery; Before connecting, make sure that the lithium battery and inverter are turned of.(It is recommended to install a circuit breaker for the power cables of the lithium battery and the inverter battery interface. Otherwise, a spark may occur.)

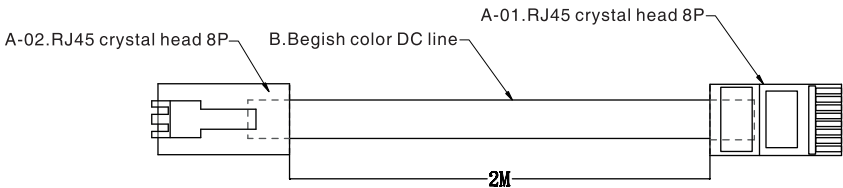

CONNECTION METHOD	
A-01	RS485
1	RS485-B
2	RS485-A
3	GND
Empty PIN is not connected	

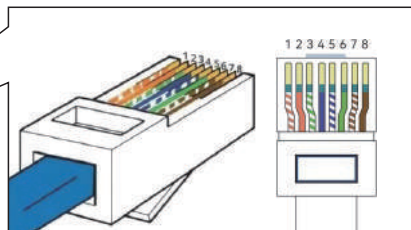

The lithium battery communication cable interface is shown in the figure

Inverter connection port

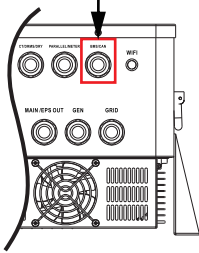

(8KW/10KW
Wiring Diagram)

Inverter connection port

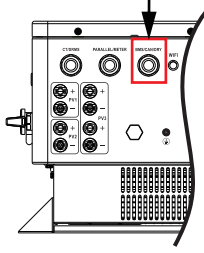

(14KW/16KW
Wiring Diagram)

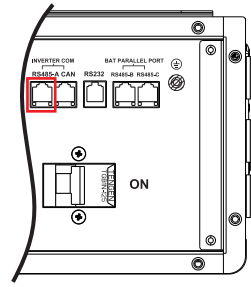

(Lithium battery
connection diagram)

4.10 Dry Contact Signa

There is one dry contact (3A/250VAC) available on the rear panel. it could be used to deliver signal to external device when battery voltage reaches warning level.

Unit Status	Condition	Dry contact port:		
		NC&C	NO&C	
Power Off	Unit is off and no output is powered	Close	Open	
Power On	Mains mode	Close	Open	
	Non-mains mode	Battery voltage < stop discharge voltage or stop discharge SOC	Open	Close
		Battery voltage > Re-discharge voltage or Re-discharge SOC	Close	Open

5. OPERATION

5.1 Power ON/OFF

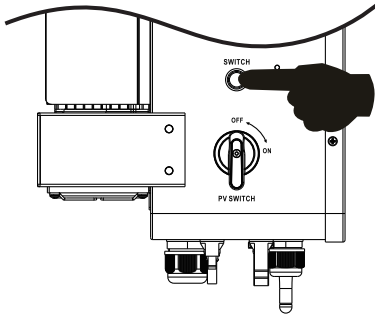

(8KW/10KW Wiring Diagram)

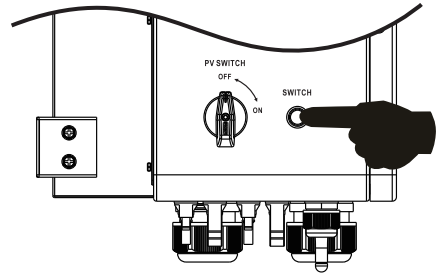

(14KW/16KW Wiring Diagram)

Once the unit has been properly installed, simply press on switch(located on the button of the case) to turn on the unit.

5.2 Operation And Display Panel

The operation and display panel, shown in below chart, is on the front panel of the inverter. It includes second indicators, four function keys and a LCD display, indicating the operating status and input/output power information.

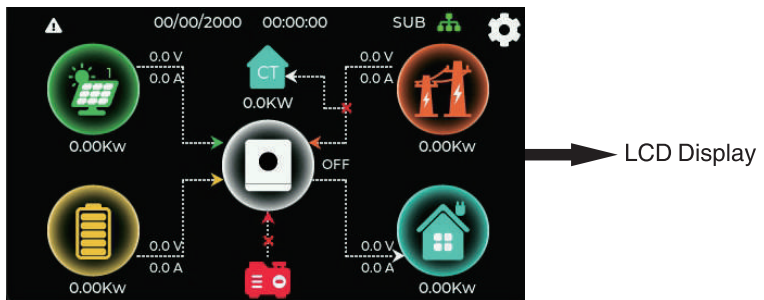

Indicator Light

Indicator Light			Messages
BACKUP ●	Green	Solid On	Output is powered by battery or PV in battery mode.
GRID ●	Green	Solid On	Output is powered by utility in Line mode.
CHG ●	Green	Solid On	Battery is fully charged.
		Flashing	Battery is charging.
FAULT ●	Red	Solid On	Fault occurs in the inverter.
		Flashing	Warning condition occurs in the inverter.

Function keys







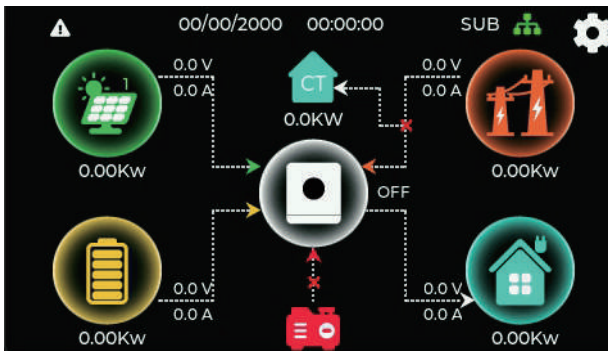

Function key	Description
☰ ESC	To exit setting mode
▲ UP	To go to previous selection
▼ DOWN	To go to next selection
↵ ENTER	To confirm the selection in setting mode or enter setting mode

5.3 LCD Display Icons

Main Screen

The LCD is touchscreen, below screen shows the overall information of the inverter.



Icon	Function description
	The icon indicates whether the system is under normal operation or not, displaying "ON" for normal status.
	Indicate each PV input voltage, current, power.
	Indicate the battery voltage, current, power.
	Indicate the grid voltage, current, power.
	Indicate the load voltage, current, power.
	Indicate the gen.(The icon is not displayed when the gen's voltage is below 50V.)
	History Error Icon. By clicking this icon, you can enter History Error Page which show History Error Code.
00/00/2000 00:00:00	The data and local time that must be set during commissioning.
	Page screen which including Battery Type, Battery Charge, Battery Discharge, Work Mode, Time Of Use ,Grid Setting, Basic Setting , History Error.
SUB	Work mode.
	Indicate the CT power.(The icon is not displayed when the extern CT is not be choosed.)

The main screen includes the icons for PV (left up), grid (right up), load (right bottom) and battery (left bottom). It also displays the energy flow direction by moving dots.

Some clarifications about the system status are as follows:

- 1.PV power will always be positive.
- 2.In single inverter system, load power will always be positive.
- 3.A negative Grid power means energy being exported to the grid (sold), whereas positive means energy being imported form the grid (purchased).
- 4.Negative battery power means charge, positive means discharge.

5.4 LCD operation flow chart

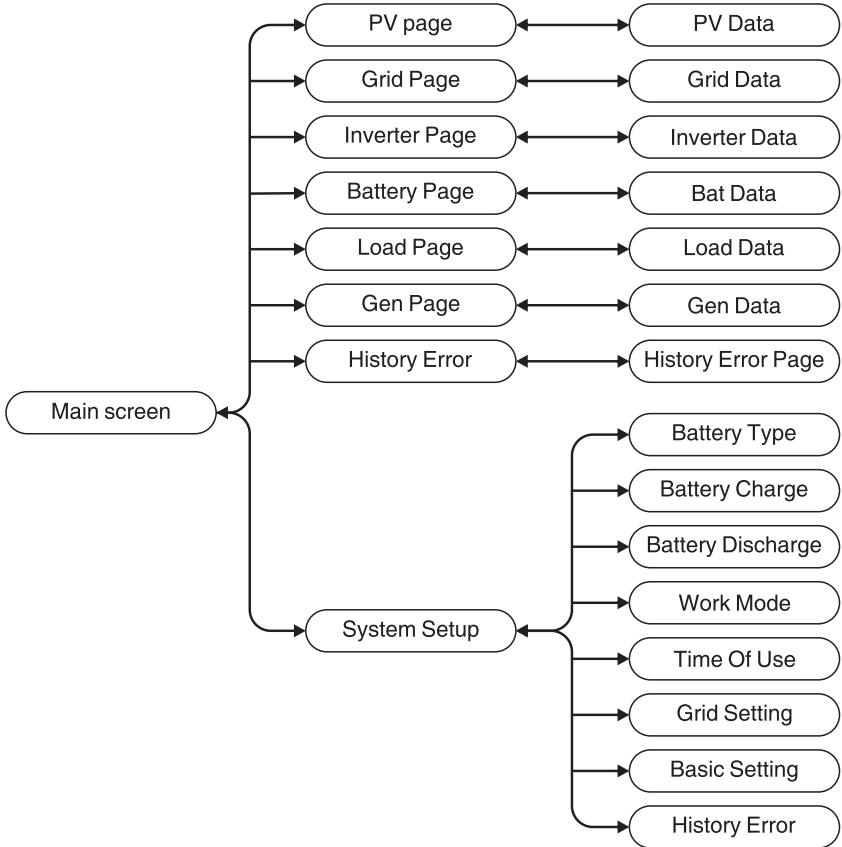

5.5 LCD Display Setting



5.5.1 Detail Page

Click the icon on the screen of LCD display, you can enter the detail page of PV, Grid, inverter Bat, and Load.

LCD display	Description
	<p>This is PV panel data page.</p> <ol style="list-style-type: none"> 1.Voltage, current, power of each MPPT. 2.Daily and total production. 3.PV power curve for hour, daily, monthly, yearly.

	<p>This is grid data page.</p> <ol style="list-style-type: none"> 1.Voltage, current, power, frequency, of grid. 2.You can choose sell or buy. It will show you sell today and sell total production or buy today and buy total production. Sell: Energy from inverter to grid. Buy: Energy from grid to inverter. 3.Grid power curve for hour, daily, monthly, yearly.
	<p>This is inverter data page.</p> <ol style="list-style-type: none"> 1.INV BUS, INV HBUS voltage, leakcurrent, INV power and INV state. 2.Air temperature, INV temperature, PV temperature, LLC temperature, Charge temperature. 3.Turn on the machine button. Holding the button 2 seconds, it will turn off the machine.
	<p>This is bat data page.</p> <ol style="list-style-type: none"> 1.Bat voltage, charge current, discharge current, power. 2.Li-BMS.
	<p>This is load data page.</p> <ol style="list-style-type: none"> 1.Load voltage, current, power, frequency. 2.Daily and total production. 3.Load power curve for hour, daily, monthly, yearly.
	<p>This is gen data page.</p> <ol style="list-style-type: none"> 1.Gen voltage, current, power, frequency. 2. Daily and total production. <p>(*Note: The generator is operating in single mode.)</p>

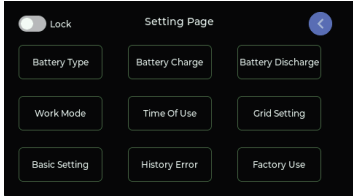
5.5.2 System Setting Page

LCD display	Description
	<p>This is system setting menu page.</p>
	<p>When we flip the “Lock” switch, access to system settings asks us to enter a password. Password: 123456</p>

5.5.3 Battery Setting Page

LCD display	Description
	<p>This is Bat Type Page.</p> <p>Bat Type: Include AGM, FLOOD, User and Lithium.</p> <p>User: If “User-Define” is selected, battery charge voltage and under voltage can be setup.</p> <p>PACE_485: If selected “Lithium” battery communication connection for PACE 485 BMS.</p> <p>PYLON_485: If selected, Lithium battery communication connection for PYLON_485 BMS.</p> <p>EQ En: Battery equalization switch. Only effective when the battery type in “FLOOD” or “user” mode.</p> <p>BMS Error: When the lithium battery fails ,turn off the machine.</p> <p>Lithium Active: When the solar energy or Line exists, set this item to Lithium, and the lithium battery will be activated for 3 minutes.</p> <p>EPS Mode: EPS Mode switch.</p> <p>LI Protocol: This is the BMS communication protocol code. “00” is PYLON_485, “01” is PACE_485.</p>

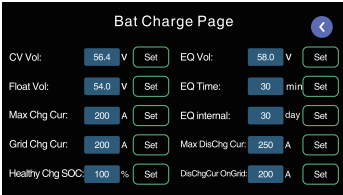
	<p>BMS Share: When inverters are connected in parallel, the inverter without a lithium battery communication connection should be set to slave in this setting item, while the one with the communication connection should be set to master.</p>
	<p>This is Bat Charge Page.</p> <p>Constant Voltage: Bulk charging voltage. If “User” is selected in “Bat Type Page”, this program can be setup. Setting range is from 48.0V to 60.0V.(default:56.4V)</p> <p>Float Voltage: Battery full charging voltage. If “User” is selected in “Bat Type Page”, this program can be setup. Setting range is from 48.0V to 60.0V.(default:54V)</p> <p>Maximum Charging Current: To configure total charging current for solar and utility chargers. Setting range is from 10A to 190A for 8KW model,10A to 190A for 10KW model,10A to 220A for 14KW model,10A to 250A for 16KW model. (default: the 8KW/10KW is 190A, the 14KW/16KW is 200A.)</p> <p>Grid Charging Current: Maximum utility charging current. Setting range is from 2A to 250A.(default:200A)</p> <p>(*Note: If setting value maximum charging current is smaller than that grid charging current, the inverter will apply charging current from maximum charging current for utility charger.)</p> <p>Healthy Charging SOC: The maximum lithium charging SOC. If the charging SOC of the lithium has reached the setting SOC, the lithium will be stopped to charge. Setting range is from 80% to100%.(default:100%)</p> <p>Battery Equalization Voltage: Setting range is from 48.0V to 60.0V.(default:58.0V)</p> <p>Battery Equalized Timeout: Setting range is from 5 min to 200 min.(default:30 min)</p> <p>Equalization Interval: Setting range is from 0 to 90 days.(default:30 days)</p> <p>Max Discharging Current: Battery maximum discharge current. Setting range is from 10A to 190A for 8KW model,10A to 190A for 10KW model,10A to 220A for 14KW model,10A to</p>

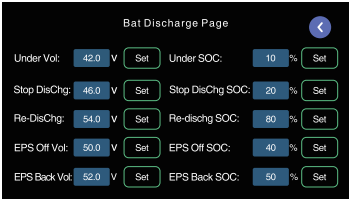
	<p>260A for 16KW model.(default: the 8KW/10KW is 190A, the 14KW/16KW is 200A.)</p> <p>Dischgcur onGrid: the limit discharge current when Grid power is available and work mode is “self”. When grid power is available it will use the smaller between “Dischg cur” and “Dischgcur onGrid” to limit the battery discharge current.Setting range is from 10A to 190A for 8KW model,10A to 190A for 10KW model,10A to 220A for 14KW model,10A to 260A for 16KW model.(default: the 8KW/10KW is 190A, the 14KW/16KW is 200A.)</p> <p>(*Note: If the battery discharge current over the setting max discharge current, overload will be reported after 10 seconds.)</p>
 <p>The screenshot shows the 'Bat Discharge Page' with the following settings:</p> <ul style="list-style-type: none"> Under Vol: 42.0 V (Set) Under SOC: 10 % (Set) Stop DisChg: 46.0 V (Set) Stop DisChg SOC: 20 % (Set) Re-DisChg: 54.0 V (Set) Re-dischg SOC: 80 % (Set) EPS Off Vol: 50.0 V (Set) EPS Off SOC: 40 % (Set) EPS Back Vol: 52.0 V (Set) EPS Back SOC: 50 % (Set) 	<p>This is Bat Discharge Page.</p> <p>Under Voltage/Under SOC: Low DC cut-off voltage/SOC.If “user” is selected in “Battery Type Page”,under voltage can be setup. Under Voltage Setting range is from 40.0V to 52.0V. (default:42V)</p> <p>When the “Lithium” mode is selected,the lithium SOC is smaller than setting percentage, the machine will be turn off the output in off grid mode.After turning off the output and you want to restart, the SOC of the lithium battery should be 10% larger than the setting value. Setting range is from 0% to 90%.(default:10%)</p> <p>Low DC cut-off voltage will be fixed to setting value no matter what percentage of load is connected.</p> <p>Stop Discharge Voltage/Stop Discharge SOC: Setting voltage/SOC point back to utility source when selecting “SBU priority” or “MKS” in “Work mode setting”.</p> <p>Stop Discharge Voltage setting range is from 42V to 52.5V.(default:46V)</p> <p>Stop Discharge SOC setting range is from 0% to 90%.(default:20%)</p> <p>Re-Discharge voltage/Re-discharge SOC: Setting voltage/SOC point back to battery mode when selecting “MKS” or “SBU” in “work mode setting”.</p> <p>Re-Discharge voltage setting range is from 48V to 58.5V.(default:54V)</p>

	<p>Re-discharge SOC setting range is from 5% to 95%. (default:80%)</p> <p>EPS Off Voltage/EPS Off SOC: Select “EPS Mode” is in “Bat Type Page”. When the battery voltage or state of charge (SOC) is lower than the “EPS Off Voltage” or “EPS Off SOC”, the device will cut off the main load output. After the main output is disconnected, to restore the output, the lithium battery SOC must be charged to the set value of “EPS Back SOC”, or the battery voltage must be charged to the set value of “EPS Back Vol”.</p> <p>EPS Off Voltage setting range is from 40V to 52V. (default:50V)</p> <p>EPS Off SOC setting range is from 0% to 90%. (default:40%)</p> <p>(*Note: For lithium batteries, refer to Under Voltage SOC, Stop Discharge SOC, Re-discharge SOC, and EPS Off SOC. For other batteries, refer to Under Voltage, Stop Discharge Voltage, Re-discharge Voltage, and EPS Off Voltage.)</p>
--	--------------------------------------------------------------------------------------------------------------------------------------------------------------------------------------------------------------------------------------------------------------------------------------------------------------------------------------------------------------------------------------------------------------------------------------------------------------------------------------------------------------------------------------------------------------------------------------------------------------------------------------------------------------------------------------------------------------------------------------------------------------------------------------------------------------------------------------------------------------------------------------------------------------------------

5.5.4 Work Mode Setting

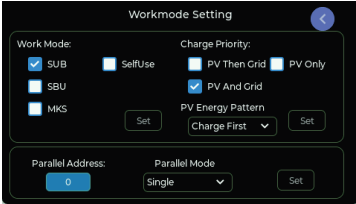
LCD display	Description
	<p>Work Mode</p> <p>SUB: Solar energy provides power to the loads as first priority. If solar energy is not sufficient to power all connected loads, utility will supply power to the loads at the same time. (default) Battery provides power to the loads only when any one condition happens: -Solar energy and utility is not available. -Solar energy is not sufficient and utility is not available.</p> <p>SBU: Solar energy provides power to the loads as first priority. If solar energy is not sufficient to power all connected loads, battery energy will supply power to the loads at the same time. Utility provides power to the loads only when battery voltage drops to the “Stop-Discharge voltage” in “Battery Discharge Page” .</p> <p>MKS: When solar is available, Refer to “SBU” mode; When solar is not available, refer to “SUB” mode.</p>

	<p>Selfuse: When solar is available, solar and battery will supply power to the loads at the same time. If solar and battery energy are not sufficient to power all connected loads, utility will supply power to the loads. When solar is not available, battery will supply power to the loads. (*Note 1: If opening the “Sell To Grid” in “Selfuse mode”, battery can sell the energy to grid. If opening the “Only PV Sell”, battery will can’t sell to grid.</p> <p>*Note 2: When in SBU /MKS mode and the PV system is unavailable, if you turn on the overload bypass function in Wi-Fi app, when the battery discharge current exceeds the setting maximum battery discharge current, it will back to the grid mode.</p> <p>*Note 3: If the PV energy has already met the load requirements, the remaining energy will be used to charge the battery. If the PV energy has already met both the load requirements and the battery charging needs, then the remaining PV energy will be sold to the grid electricity.)</p> <p>Charge Priority</p> <p>PV Then Grid: Solar energy will charge battery as first priority. Utility will charge battery only when solar energy is not available.</p> <p>PV Only: Solar energy will be the only charger source no matter utility is available or not.</p> <p>PV And Grid: Solar energy and utility will charge battery at the same time.(default)</p> <p>PV Energy Pattern: Priority of PV power usage. When in “Grid mode”, the default energy pattern is “Load first”, this setting will be valid.</p> <p>Charge First: PV power is firstly used to charge the battery, and the excess power will be used to power the load. If PV power is insufficient, grid will make supplement for battery and load simultaneously.</p> <p>Load First: PV power is firstly used to power the load, and the excess power will be used to charge the battery. If PV power is insufficient, Grid will provide power to the load.</p> <p>Parallel Mode: If a set of inverters are connected to inverter 1, inverter 2, inverter 3, inverter 4, inverter 5, inverter 6, the function</p>
--	-----------------------------------------------------------------------------------------------------------------------------------------------------------------------------------------------------------------------------------------------------------------------------------------------------------------------------------------------------------------------------------------------------------------------------------------------------------------------------------------------------------------------------------------------------------------------------------------------------------------------------------------------------------------------------------------------------------------------------------------------------------------------------------------------------------------------------------------------------------------------------------------------------------------------------------------------------------------------------------------------------------------------------------------------------------------------------------------------------------------------------------------------------------------------------------------------------------------------------------------------------------------------------------------------------------------------------------------------------------------------------------------------------------------------------------------------------------------------------------------------------------------------------------------------------------------------------------------------------------------------------------------------------------------------------------------------------------------------------------------------------------------------------------------------------------------------------------------------------------------------------------------------------------------------------------------------------------------------------------------------------------------------------------------------------------------------------------------------------------------------------------------------------------------------------------------------------------------

	<p>needs to be enabled.</p> <p>(*Note 1:This setting can only be set by stand by mode the switch after the secondary source is started.</p> <p>*Note 2:In parallel mode, the Max Chg SOC, Dischgcur on grid, the fifth timed grid charge and battery discharge, Time Set, clear PV Data, clear Load Data, clear Grid Data, GFCI Check, Extern CT, CT Ratio, Only PV Sell, Zero To Grid, APL and UPS setting items will not synchronize to other machine.)</p>
--	-----------------------------------------------------------------------------------------------------------------------------------------------------------------------------------------------------------------------------------------------------------------------------------------------------------------------------------------------------------------------------------------------------------------------------------------------------------------------------

5.5.5 Time Of Use Page

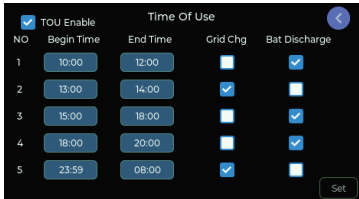
LCD display	Description
	<p>Time Of Use: It is used to program when to use grid to charge the battery, and when to discharge the battery to power the load. Only tick “TOU Enable” the follow items will take effect.</p> <p>Grid Charge: Use the grid to charge the battery in the selected period of time.</p> <p>Bat Discharge: Battery will supply power to the loads in the selected period of time.</p> <p>(*Note 1: When in “SBU” or “MKS” mode, click “Bat Discharge”and “TOU Enable”, battery will supply power to loads in off grid mode.</p> <p>*Note 2: When in “Selfuse” mode, click “Bat Discharge”and “TOU Enable”, utility will supply power to loads. If choose the “Sell Power To Grid” in “Grid setting page”, battery will sell the energy to grid.)</p>

5.5.6 Grid Setting Page

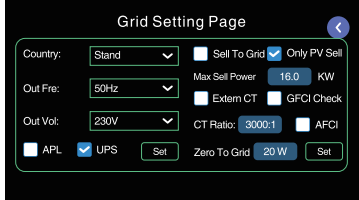
LCD display	Description
	<p>Country: You can choose different country.</p> <p>Output Frequency: You can choose 50Hz or 60Hz.(default:50Hz)</p> <p>Output Voltage: Default output voltage is 230V. The output voltage is selectable:220V,230V, 240V.(default:230V)</p> <p>Sell To Grid: Ticking the “Sell To Grid”, it will feed the power to grid.</p>

	<p>Only PV Sell: When you tick the “Sell To Grid” and the same time tick the “Only PV Sell” in “Self” mode, it will only PV sell to grid and battery will not sell to grid.</p> <p>Max Sell Power: The maximum sell to grid power. Setting range is 0KW-16KW.</p> <p>Extern CT : Tick the “Extern CT”, it supports to connect the external CT.</p> <p>GFCI Check: Tick “GFCI check”,the machine will check GFCI leak current.</p> <p>CT Ratio: CT ratio setting. You can set different ratios to adapt to different Cts. Setting range is from 100:1 to 30000:1(default:3000:1)</p> <p>AFCI: Arc detection function is optional.</p> <p>APL: If selected, acceptable AC input voltage range will be within 90~280Vac.</p> <p>UPS: If selected, acceptable AC input voltage range will be within 170~280Vac(default:UPS)</p> <p>Zero To Grid: It tells the grid output power. Recommend to set it as 20-100W to ensure the inverter won’t feed power to grid. Setting range is from 0W to 500W.(default:20W)</p> <p>(*Note: when “Extern CT” function is on, if the load power is negative, check whether the CT direction is connected in reverse.)</p>
--	------------------------------------------------------------------------------------------------------------------------------------------------------------------------------------------------------------------------------------------------------------------------------------------------------------------------------------------------------------------------------------------------------------------------------------------------------------------------------------------------------------------------------------------------------------------------------------------------------------------------------------------------------------------------------------------------------------------------------------------------------------------------------------------------------------------------------------------------------------------------------------------------------------------------------------------------------------------------------------------------------------------------------------------------------------------------------------------------------------------------------------------------------------------------------------------------------------------------

5.5.7 Basic Setting Page

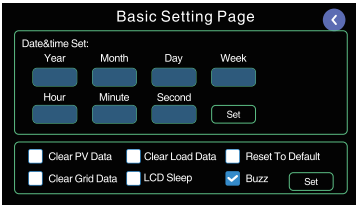
LCD display	Description
	<p>Data&Time Set: Enable the inverter to automatically synchronize cloud platform time.</p> <p>Clear PV Data: Clear all PV power generation.</p> <p>Clear Load Data: Clear all Load power generation.</p> <p>Reset To Default: Reset all parameters of the inverter.</p> <p>Clear Grid Data: Clear all Grid power generation.</p> <p>LCD Sleep: If check this box, LCD will sleep after 3 minutes.</p> <p>Buzz: Used to turn on or off the beep sound in inverter’s alarm status.</p>

5.5.8 History Error Page

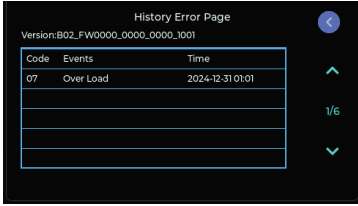
LCD display	Description
	<p>This page show software version number and history error code.</p>

5.6 Fault Reference Code

Fault Code	Fault Event	Description
01	Fan Lock.	Fan is lock when inverter is on.
02	Over Temp.	Over temperature.
03	Bat Vol High.	Battery voltage is too high.
05	Output Short.	Output Short circuited.
06	Output Vol High.	Output voltage is too high.
07	Over Load.	Over load (note: if the alarm is overloaded more than three times, the machine will not restart again.)
08	Bus Vol Over.	Bus voltage is over.
12	Soft Start Fail.	Soft start fail.
15	Internal SCI Fail.	Internal communication fault.
17	LLC Fault.	LLC short-circuit.
18	BMS Error.	Lithium communication fault.
19	PV current over.	PV current is over.
21	GFCI Fault.	Leakage current fault.
23	PV ISO Fault.	PV isolation resistance is too low.
25	RELAY Check Fault.	Relay self-check failed.
51	Over Current.	Over current or surge.
52	Bus Vol Under.	Bus voltage is too low.
53	Inv Soft Fail.	Inverter soft start fail.
55	Load DC Vol Over.	Over DC voltage in Ac output.
57	Current Hall Fault.	Current sensor failed.
58	Output Vol Under.	Output voltage is too low.
59	PV Vol Over.	PV voltage is over limitation.
60	Parallel Neg Power.	Parallel failure.

71	Parallel Version Diff.	Parallel version is inconsistent.
75	Parallel Setting Fault.	Parallel Settings are inconsistent.
80	Parallel CAN Loss.	Parallel communication failure.
81	Host Line Loss.	Host signal Loss.
82	Syn phase Loss.	Synchronization signal Loss.
86	Parallel Mode Diff.	Parallel mode is incorrect.
99	Other Fault.	Other fault.

5.7 Warning Indicator

Warning Event	Audible Alarm	Icon Flashing
Low battery.	Beep once every second.	Battery low warning.
Overload .	Beep once every second.	Overload.
The battery is being activated.	Beep once every second.	Battery active.
Battery is equalizing.	Beep once every second.	Battery equalized.
BMS no communication.	Beep once every second.	BMS no communication.
PV energy weak.	Beep once every second.	PV weak warning.
Battery energy weak.	Beep once every second.	Battery weak warning.
CT not connected.	Beep once every second.	CT not connected.
CT wrong direction.	Beep once every second.	CT wrong direction.
Output power derating.	Beep once every second.	Output power derating.

6.SPECIFICATIONS

Table 1 Line Mode Specifications

INVERTER MODEL	8KW	10KW	14KW	16KW
Input Voltage Waveform	Sinusoidal (utility or generator)			
Nominal Input Voltage	230Vac			
Low Loss Voltage	170Vac±7V(UPS) 90Vac±7V (APL)			
Low Loss Return Voltage	185Vac±7V(UPS) 100Vac±7V(APL)			
High Loss Voltage	280Vac±7V			
High Loss Return Voltage	258Vac±7V			
Max AC Input Voltage	300Vac			
Nominal Input Frequency	50Hz/60Hz(Auto detection)			
Low Loss Frequency	45±1Hz			
Low Loss Return Frequency	46±1Hz			
High Loss Frequency	65±1Hz			
High Loss Return Frequency	63±1Hz			
Output Short Circuit Protection	Circuit Breaker			
Efficiency(Line Mode)	>95%(Rated R load, battery full charged)			
Transfer Time	10ms typical (UPS)/26ms typical (APL)			
Output power derating: When AC input voltage drops to 170V, the output power will be derated.	<p>The graph plots Output Power against Input Voltage. The x-axis has markers at 90V, 170V, and 280V. The y-axis has markers for 50% Power and Rated Power. The curve starts at 90V with a power level of 50%. It then rises linearly to reach the Rated Power level at 170V. From 170V to 280V, the output power remains constant at the Rated Power level.</p>			

Table 2 Inverter Mode Specifications

INVERTER MODEL	8KW	10KW	14KW	16KW
Rated Output Power	8KW	10KW	14KW	16KW
Output Voltage Waveform	Pure Sine Wave			
Output Voltage Regulation	230Vac±5%			
Output Frequency	50Hz/60Hz			
Peak Efficiency	93%			
Overload Protection	3s@ ≥ 150% load; 5s@ 101%~150% load			
Surge Capacity	2* rated power for 5 seconds			
Nominal DC Input Voltage	48.0Vdc			
Cold tart Voltage	46.0Vdc			

Low DC Warning Voltage @ load < 50% @ load ≥ 50%	44.0Vdc 42.0Vdc
Low DC Warning Return Voltage @ load < 50% @ load ≥ 50%	45.0Vdc 44.0Vdc
Low DC Cut-off Voltage @ load < 50% @ load ≥ 50%	41.0Vdc 40.0Vdc
High DC Recovery Voltage	62.0Vdc
High DC Cut-off Voltage	63.0Vdc
No Load Power Consumption	75W

Table 3 Two Load Output Power

INVERTER MODEL	8KW	10KW	14KW	16KW
Full Load	8000W	10000W	14000W	16000W
Maximum Main Load	8000W	10000W	14000W	16000W
Maximum Second Load (battery model)	5600W	7000W	9800W	11200W
Main Load Cut off Voltage	50Vdc			
Main Load Return Voltage	52Vdc			

Table 4 Charge Mode Specifications

Utility Charging Mode					
INVERTER MODEL	8KW	10KW	14KW	16KW	
Battery Type	Lead-acid or Lithium-ion				
AC Charging Current (Max)	190A	220A	250A	250A	
Bulk Charging Voltage	Flooded Battery	58.4Vdc			
	AGM / Gel Battery	56.4Vdc			
Floating Charging Voltage	54.0Vdc				
MPPT Solar Charging Mode					
INVERTER MODEL	8KW	10KW	14KW	16KW	
Max.PV Array Power	PV1 Channel:	5400W	8100W	5400W	5400W
	PV2 Channel:	5400W	8100W	5400W	5400W
	PV3 Channel:	/	/	10800W	10800W
IMax.PV	PV1 Channel:	18A	27A	18A	18A
	PV2 Channel:	18A	27A	18A	18A
	PV3 Channel:	/	/	36A	36A
Nominal PV Voltage	300Vdc				

PV Array MPPT Voltage Range	80Vdc~500Vdc			
Max. PV Array Open Circuit Voltage	520Vdc			
Max Charging Current(AC charger plus solar charger)	135Amp	190Amp	220Amp	250Amp

Table 5 Grid-Tie Operation

INVERTER MODEL	8KW	10KW	14KW	16KW
Nominal Output Voltage	220/230/240Vac			
Feed-in Grid Voltage Range	195.5Vac~253Vac			
Feed-in Grid Frequency Range	49Hz~51Hz			
Nominal Output Current	35A	43.5A	60.9A	69.5A
Power Factor Range	>0.99			
Maximum Conversion Efficiency (DC/AC)	98%			

Table 6 General Specifications

INVERTER MODEL	8KW	10KW	14KW	16KW
Safety EMC/Standard	EN IEC 61000-6-1,EN IEC 61000-6-3, EN 61000-3-12,EN IEC 61000-3-11, EN 62109-1,EN 62109-2, IEC 61727,EN IEC 62116			
Operating Temperature Range	-10°C ~ 50°C			
Storage temperature	-15°C~ 60°C			
Humidity	5% to 95% Relative Humidity(Non-condensing)			

7.TROUBLE SHOOTING

Problem	LCD/LED/Buzzer	Explanation /Possible cause	What to do
Buzzer beeps continuously and red LED is on.	Fault code 01	Fan fault.	Replace the fan.
	Fault code 02	The temperature exceeds the protection point.	Check whether the air flow of the unit is blocked or whether the ambient temperature is too high.
	Fault code 05	Output short circuited.	Check if wiring is connected well and remove abnormal load.
	Fault code 06/58	Output abnormal. (Inverter voltage below than 190Vac or is higher than 260Vac.)	1. Reduce the connectedload. 2. Return to repair center.
	Fault code 07	Overload error. The inverter is overload 102% and time is up.	Reduce the connected load by switching off some equipment.
	Fault code 08/53/57	Internal components failed.	Return to repair center.
	Fault code 51	Over current or surge.	Restart the unit, if the error happens again, please return to repair center.
	Fault code 52	Bus voltage is too low.	
Fault code 55	Output voltage is unbalanced.		

APPENDIX I: PARALLEL FUNCTION

1.INTRODUCTION

This inverter can be used in parallel with two different operation modes.

1.Parallel operation in single phase is with up to 6 units. The supported maximum output power is 96 KW/96 KVA.

2.Three-phase parallel, up to three units working together.

2.MOUNTING THE UNIT

When installing multiple units, please follow below chart.

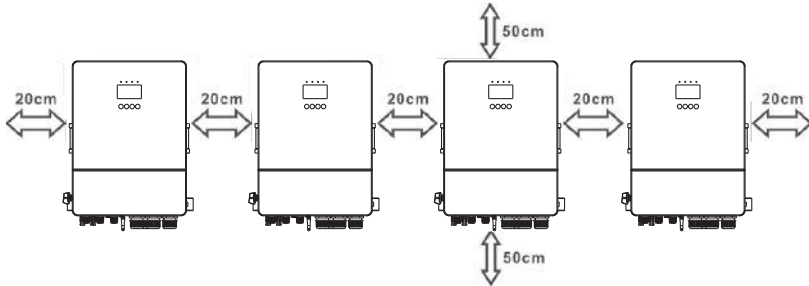

*NOTE:

For proper air circulation to dissipate heat, allow a clearance of approx, 20 cm to the side and approx. 50 cm above and below the unit. Be sure to install each unit in the same level.

3.WIRING CONNECTION

When installing multiple units, please follow below chart.

The cable size of each inverter is shown as below:

Recommended battery cable and terminal size for each inverter:

Ring terminal:

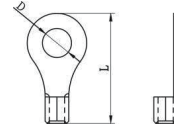

MODEL	Wire size	Cable (mm ²)	Torque value(max)
8KW/10KW	3/0AWG	85.01	18.0N·m
14KW/16KW	2 x 0AWG	53.49	12.5N·m

Recommended AC input and output cable size for each inverter:

MODEL	Wire size	Cable (mm ²)	Torque value(max)
8KW/10KW	6AWG	13.3	2.5N·m
14KW/16KW	2AWG	33.62	10.0N·m

You need to connect the cables of each inverter together, Take the battery cables for example: You need to use a connector or bus-bar as a joint to connect the battery cables together, and then connect to the battery terminal. The cable size used from joint to battery should be X times cable size in the tables above. "X" indicates the number of inverters connected in parallel.

Regarding AC input and output, please also follow the same principle.

⚠ WARNING

- It's REQUIRED to connect battery for parallel operation.
- Be sure the length of all battery cables is the same. Otherwise, there will be voltage difference between inverter and battery to cause parallel inverters not working.

⚠ CAUTION

- Please install the breaker at the battery and AC input side. This will ensure the inverter can be securely disconnected during maintenance and fully protected from over current of battery or AC input.

Recommended breaker specification of battery for each inverter:

MODEL	8KW	10KW	14KW	16KW
1 unit*	51.2V 205Ah	51.2V 300Ah	51.2V 300Ah	51.2V 300Ah

Recommended breaker specification of AC input with single phase:

MODEL	8KW	10KW	14KW	16KW
1 unit*	50A/230Vdc	70A/230Vdc	90A/230Vdc	150A/230Vdc

*Note 1:

If you want to use only one breaker at the output side for the whole system, the rating of the breaker should be X times current of 1 unit, "X" indicates the number of inverters connected in parallel.

Recommended battery capacity:

Inverter parallel numbers	2	3	4	5	6
Battery Capacity	300Ah	400Ah	600Ah	600Ah	600Ah

4. PARALLEL CONNECTION

*Note: The wiring diagram in this section takes the 16KW model as an example, and the wiring principles for other models are the same.

4.1 Parallel Operation in Single phase

Two inverters in parallel:

Power Connection

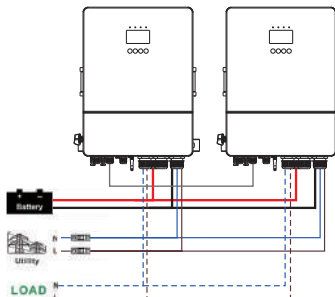

Communication Connection

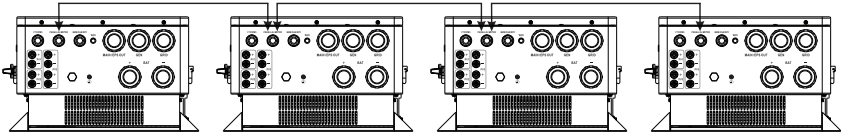

Five inverters in parallel:
Power Connection

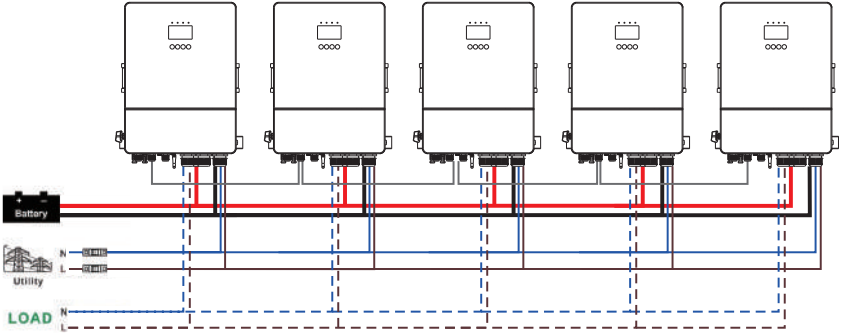

Communication Connection

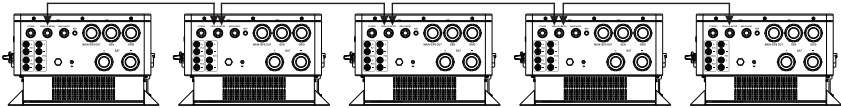

Six inverters in parallel:
Power Connection

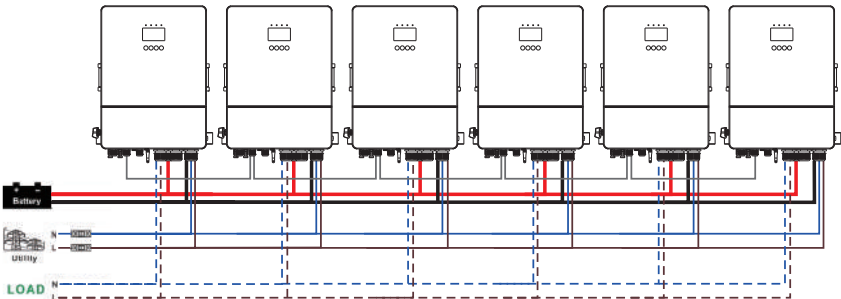

Communication Connection

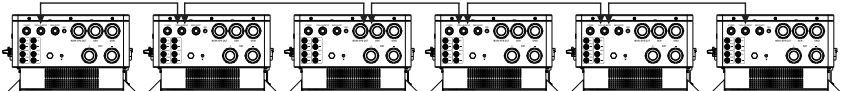

4.2 Support 3-phase equipment

One inverter per phase:

Power Connection

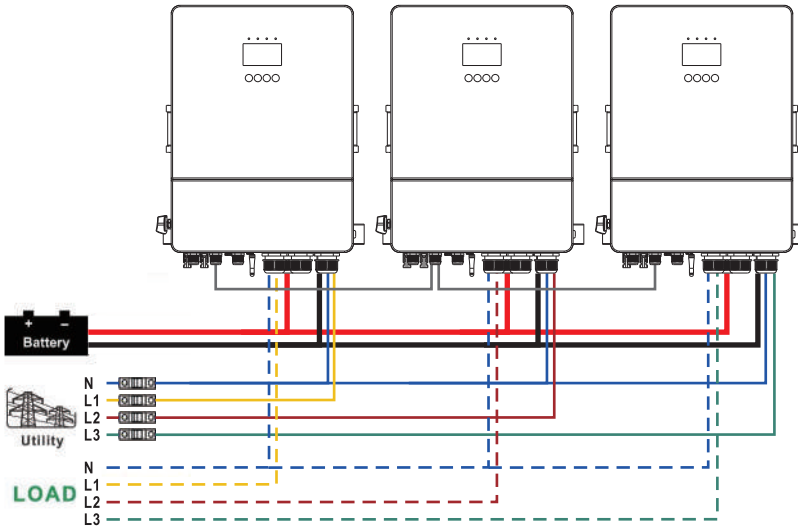

Communication Connection

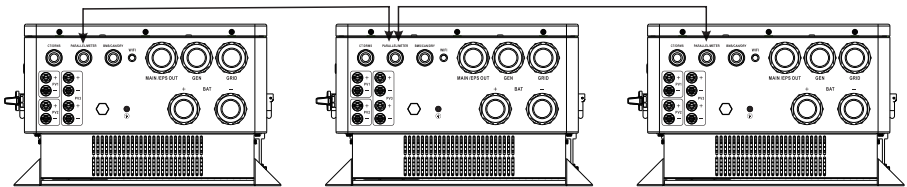

*Note:

1. You need to connect all inverters to the “PARALLEL” port; otherwise, the inverters fail or are damaged.
2. If you need to increase the number of inverters in a phase, add “PARALLEL” as described above, and add other cables directly to the line of the phase.
3. Ensure that there is at least one inverter per phase before the machine can start output normally.
4. Single-phase parallel support six unit working together. Three-phase parallel only support three unit working together.
5. The first and the last of parallel inverter’s communication board’s “SW1” should be open, please set it to on.

5. PV CONNECTION



Please refer to user manual of single unit for PV Connection.

⚠ CAUTION

- Each inverter should connect to PV modules separately.

6. LCD SETTING AND DISPLAY

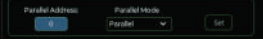
Setting Program:

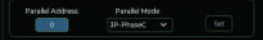
Program	Description	Selectable option	
Parallel mode	AC output mode*This setting is able to set up only when the inverter is in standby mode. Be sure that on/off switch is in "OFF" status.	Single 	When the unit is operated alone, please select "Single" in "Parallel Mode" in "work mode setting" page.
		Parallel 	When the units are used in parallel for single phase application, please select "Parallel" in "Parallel Mode" in "work mode setting" page.
		3P-PhaseA: 	When the units are operated in 3-phase application, please choose "3PX" to define each inverter. Please select "3P-PhaseA" in "Parallel Mode" for the inverters connected to L1 phase, "3P-PhaseB" in "Parallel Mode" for the inverters connected to L2 phase and "3P-PhaseC" in "Parallel Mode" for the inverters connected to L3 phase.
		3P-PhaseB: 	
		3P-PhaseC: 	

7.COMMISSIONING

7.1 Parallel in single phase

Step 1:Check the following requirements before commissioning:

- Correct wire connection.
- Ensure all breakers in Line wires of load side are open and each Neutral wires of each unit are connected together.

Step 2:Turn on each unit and set “Parallel” in “Parallel Mode” in “work mode setting” page of each unit. And then shut down all units.

*NOET:

It’s necessary to turn off switch when setting LCD program, Otherwise, the setting cannot be programmed.

Step 3:Turn on each unit.

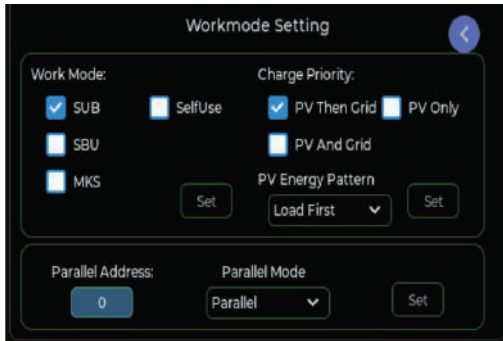

Step 4:

Switch on all Ac breakers of line wires in Ac input, It’s better to have all inverters connect to utility at the same time.Otherwise, the mains of all inverters cannot be connected. The inverters can work properly only after the mains of all inverters are correctly connected. If detecting AC connection, they will work normally.

Step 5:

If there is no more fault alarm, the parallel system is completely installed.

Step 6:

Please switch on all breakers of Line wires in load side. This system will start to provide power to the load.

7.2 Support three-phase equipment

Step 1: Check the following requirements before commissioning:

- Correct wire connection.
- Ensure all breakers in Line wires of load side are open and each Neutral wires of each unit are connected together.

Step 2:

Turn on all units and configure LCD “Parallel Mode”in “work mode setting” page as 3P-PhaseA, 3P-PhaseB and 3P-PhaseC sequentially. And then shut down all units.

***NOET:**

It's necessary to turn off switch when setting LCD program. Otherwise, the setting cannot be programmed.

Step 3:

Turn on all units sequentially.

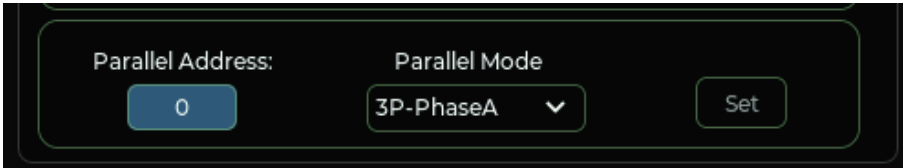

LCD display in L1-phase unit

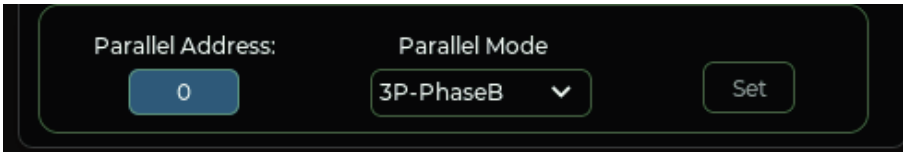

LCD display in L2-phase unit

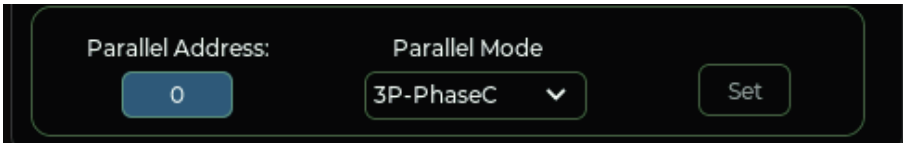

LCD display in L3-phase unit

Step 4:

Switch on all AC breakers of Line wires in AC input, If AC connection is detected and three phases are matched with unit setting, they will work normally. Otherwise, the mains will not be connected and will be connected after all the mains are matched.

Step 5:

If there is no more fault alarm, the system to support 3-phase equipment is completely installed.

Step 6:

Please switch on all breakers of Line wires in load side. This system will start to provide power to the load.

***Note 1:**

To avoid overload occurring, before turning on breakers in load side, it's better to have whole system in operation first.

***Note 2:**

Transfer time for this operation exists. Power interruption may happen to critical devices, which cannot bear transfer time.

8.TROUBLE SHOOTING

Situation		Solution
Fault Code	Fault Event Description	
71	The firmware version of each inverter is not the same.	<ol style="list-style-type: none"> 1.Update all inverter firmware to the same version. 2.Check the version of each inverter via LCD setting and make sure the CPU versions are same. If not, please contact your installer to provide the firmware to update. 3.After updating, if the problem still remains, please contact your installer.
75	Data synchronization fault.	<ol style="list-style-type: none"> 1.Check if communication cables are connected well and restart the inverter. 2.If the problem remains, please contact your installer.
80	CAN data loss.	
81	Host data loss.	
82	Synchronization data loss	
86	AC output mode setting is different.	<ol style="list-style-type: none"> 1.Switch off the inverter and check LCD setting “Parallel Mode”. 2.For parallel system in single phase, make sure no 3P-PhaseA, 3P-PhaseB and 3P-PhaseC are setted on “Parallel Mode”.For supporting three-phase system, make sure no “Parallel” is set on “Parallel Mode”. 3.If the problem remains, please contact your installer.

APPENDIX II: WI-FI CONNECTION INSTRUCTIONS

1.WIRELESS WI-FI DISTRIBUTION NETWORK

1.1 APP Download

Method 1:

Scan the QR code on the right, download the app.

Method 2:

Scan the QR code of the film on the collector.

Method 3:

Search in the application market to download the APP named “SUN WISE” for download.



1.2 Registered Account

On the App home page, click the “Sign Up”button,fill in the relevant information according to the prompt, and complete the registration.

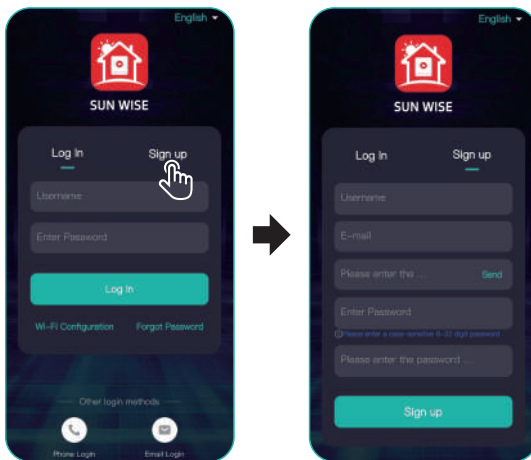

2.SUPPORTING NETWORK AND ADDING DEVICE

2.1 Wi-Fi Collector Connection Router

1.After the PWR indicator on the collector is on, turn on the mobile phone Bluetooth and SUN WISE App, click the“Wi-Fi Configuration” button to enter the “Searching” page, and the page will automatically display the nearby Bluetooth device.

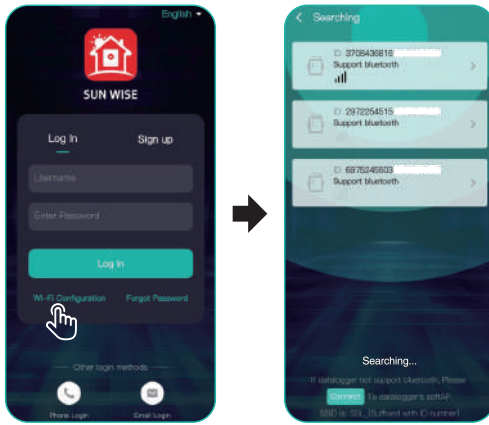

2. Select the collector that needs to be distributed, enter the matching webpage, and click the search icon, you can choose the Wi-Fi hotspot name.

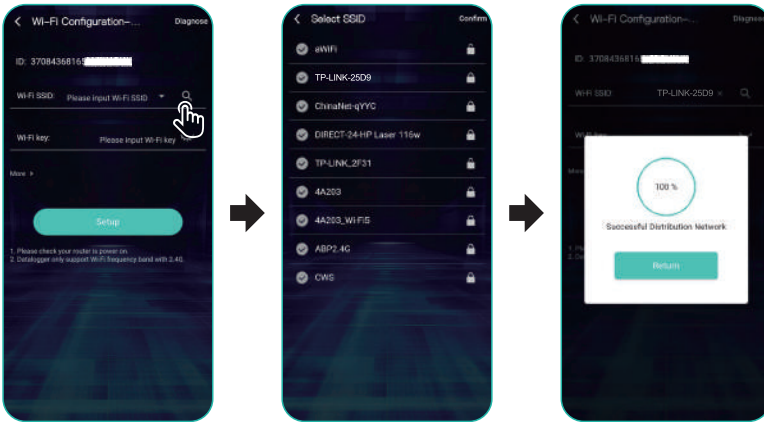

2.2 Add Device

Method 1:

1. Enter the homepage of the APP, click "+" in the upper right corner, enter the device to add the page, close the mobile phone close to the device, and the app scan the device automatically.
2. After scanning to the device, select the ID that is consistent with the ID of the collector tag, and click "Add".

*Note: Please confirm the collector ID before scanning. If the ID information is not found on the surface of the machine, you can view the ID on the matching page.

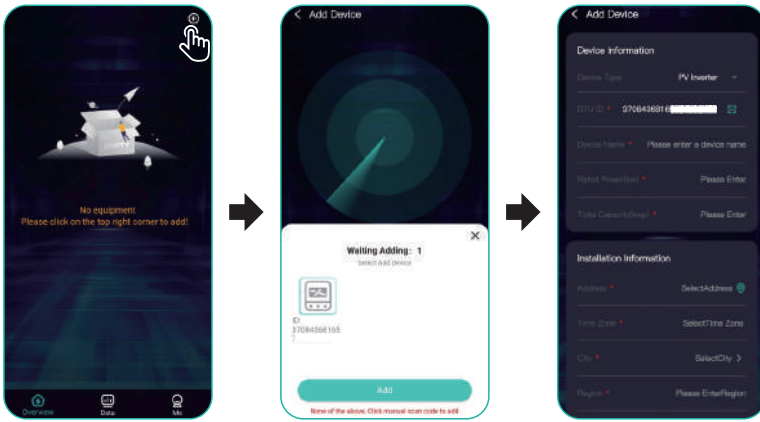

Method 2:

“Manually Add”, complete the adding device according to the interface prompt manual output collector ID, name and other information.

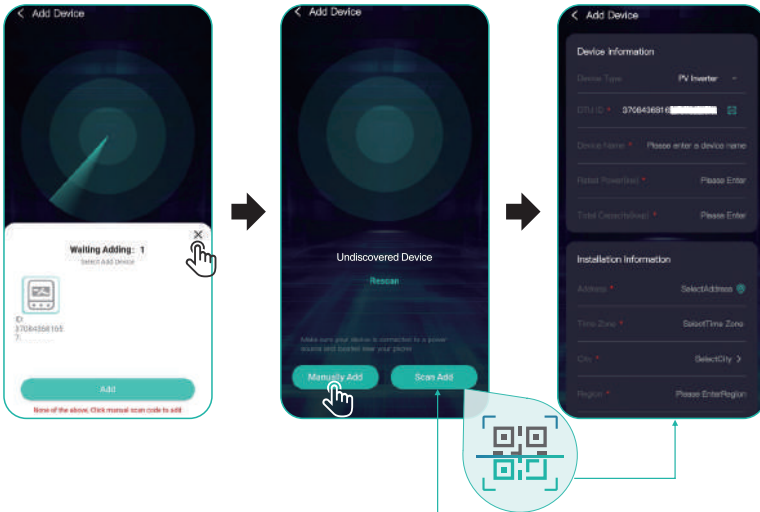

Method 3:

“Scan Add”, scan the QR code ID number of the collector film, and perform the device with the corresponding collector.

*NOTE: The QR code for the built-in Wi-Fi is located on the communication board inside the machine. You need to remove the wiring cover to access it.

3.COLLECTOR FAULT DIAGNOSE AND INDICATOR LIGHT JUDGMENT

3.1 Collector Fault Diagnose

After the device distribution network is completed or failed, you can make a failure diagnosis by clicking on the upper right “Diagnose”.

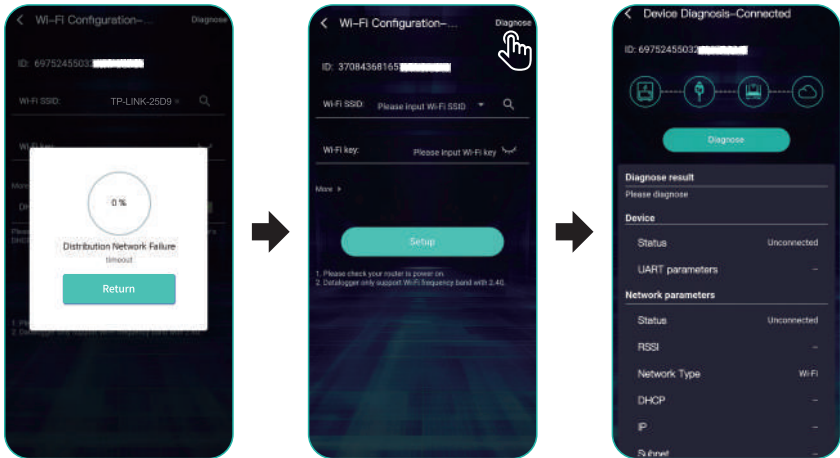

3.2 Collector Indicator Status

1.COM (serial port transmission indicator):

Off: Number of data interaction.

Off for 0.3 seconds, on for 0.9 seconds: serial output data.

Off for 0.3 seconds, on for 0.3 seconds: serial port receiving data.

On: Bi-directional transfer.

2.Net (network status indicator):

Off for 0.3 seconds, on for 3 seconds: STA mode connects the upper router.

Off for 0.3 seconds, on for 0.3 seconds: STA is not connected to the upper router.

3.SRV (server connection indicator):

On: Has been connected to the server.

Off: Uninterrupted to the server.